

System MICRO

SM-DIO | | Manual

HB400 | SM-DIO | | en | 25-10

Digital signal modules - SM M2x



YASKAWA Europe GmbH
Philipp-Reis-Str. 6
65795 Hattersheim
Germany
Tel.: +49 6196 569-300
Fax: +49 6196 569-398
Email: info@yaskawa.eu
Internet: www.yaskawa.eu.com

Table of contents

1	General	4
1.1	About this manual	4
1.2	Copyright © YASKAWA Europe GmbH	5
1.3	Safety instructions	6
2	Basics and mounting	9
2.1	Safety notes for the user	9
2.2	System conception	10
2.3	Dimensions	12
2.4	Grounding concept	14
2.4.1	Shielding	14
2.5	Mounting	16
2.5.1	Mounting CPU	16
2.5.2	Mounting the extension module	18
2.5.3	Mounting periphery module	19
2.6	Wiring	20
2.6.1	Wiring CPU	20
2.6.2	Wiring periphery module	23
2.7	Demounting	24
2.7.1	Demounting CPU	24
2.7.2	Demounting the extension module	28
2.7.3	Demounting periphery module	29
2.8	Industrial security and installation guidelines	32
2.8.1	Industrial security in information technology	32
2.8.2	Installation guidelines	34
2.9	General data for the System MICRO	36
2.9.1	Use in difficult operating conditions	38
3	Digital in-/output	39
3.1	M21-1BH00 - DI 16xDC 24V	39
3.1.1	Technical data	42
3.2	M22-1BH00 - DO 16xDC 24V 0.5A	44
3.2.1	Diagnostic data	47
3.2.2	Technical data	49
3.3	M22-1HF10 - DO 8xRelay	51
3.3.1	Technical data	54
3.4	M23-1BH00 - DI8/DO8 0.5A	56
3.4.1	Diagnostic data	59
3.4.2	Technical data	61

About this manual

1 General

1.1 About this manual

Objective and contents

The manual describes the digital signal modules SM M2x of the System MICRO.

- It describes the structure, configuration and application.
- The manual is targeted at users with good basic knowledge in automation technology.
- The manual does not replace sufficient basic knowledge of automation technology or sufficient familiarity with the specific product.
- The manual consists of chapters. Each chapter describes a completed topic.
- For guidance, the manual provides:
 - An overall table of contents at the beginning of the manual
 - References with page numbers

Documentation

In the context of the use of the pertinent Yaskawa product, the manual is to be made accessible to the pertinent qualified personnel in:

- Project engineering
- Installation department
- Commissioning
- Operation

Icons and headings

Important passages in the text are highlighted by following icons and headings:



DANGER

- Immediate danger to life and limb of personnel and others.
- Non-compliance will cause death or serious injury.



CAUTION

- Hazardous situation to life and limb of personnel and others. Non-compliance may cause slight injuries.
- This symbol is also used as warning of damages to property.



NOTICE

- Designates a possibly harmful situation.
- Non-compliance can damage the product or something in its environment.



Supplementary information and useful tips.

1.2 Copyright © YASKAWA Europe GmbH

All rights reserved

This document contains protected information of Yaskawa and may not be disclosed or used outside of an agreement made in advance with Yaskawa and only in accordance with that agreement.

This document is protected by copyright laws. Reproduction, distribution, or modification of this document or excerpts thereof is not permitted without the written consent of Yaskawa and the owner of this document, except in accordance with applicable agreements, contracts or licenses.

For permission to reproduce or distribute, please contact: YASKAWA Europe GmbH, European Headquarters, Philipp-Reis-Str. 6, 65795 Hattersheim, Germany

Tel.: +49 6196 569 300

Fax.: +49 6196 569 398

E-mail: info@yaskawa.eu

Internet: www.yaskawa.eu.com

Download Center

By entering the product order number in the '*Download Center*' at www.yaskawa.eu.com, the pertinent manuals, data sheets, declarations of conformity, certificates and other helpful information for your product can be found.

Trademarks

MICRO is a registered trademark of YASKAWA Europe GmbH.

All other trademarks, logos and service or product marks specified herein are owned by their respective companies.

General terms of use

Every effort was made by Yaskawa to ensure that the information contained in this document was complete and correct at the time of publication. Nevertheless, the information contained therein is only owed by Yaskawa as it is available at Yaskawa. Correctness is not assured by Yaskawa, the right to change the information contained herein is always reserved by Yaskawa. There is no obligation to inform the customer of any changes. The customer is requested to actively keep this documentation up to date. The use of the products covered by these instructions, together with the associated documentation, is always at the customer's own risk, in accordance with the applicable guidelines and standards. This documentation describes the hardware and software components and functions of the product. It is possible that units are described which the customer does not have. The exact scope of delivery is described in the respective purchase contract.

Document support

Contact your local representative of YASKAWA Europe GmbH if you have errors or questions regarding the content of this document. You can reach YASKAWA Europe GmbH via the following contact:

Email: Documentation.HER@yaskawa.eu

Technical support

Contact your local representative of YASKAWA Europe GmbH if you encounter problems or have questions regarding the product. If such a location is not available, you can reach the Yaskawa customer service via the following contact:

YASKAWA Europe GmbH,

European Headquarters, Philipp-Reis-Str. 6, 65795 Hattersheim, Germany

Tel.: +49 6196 569 500 (hotline)

Email: support@yaskawa.eu

1.3 Safety instructions

General safety instructions



DANGER

Danger to life due to non-compliance with safety instructions

Non-compliance with the safety instructions in the manual can result in serious injury or death. The manufacturer is not responsible for any injuries or damage to the equipment.



CAUTION

Before commissioning and operating the components described in this manual, it is essential to note the following:

- Modifications to the automation system must only be done in a voltage-free state!
- Connection and modification only by trained electricians
- National regulations and guidelines in the respective country of use must be observed and complied with (installation, protective measures, EMC, etc.)

Intended use

- It is the customer's responsibility to comply with all pertinent standards, codes, or regulations applicable to the use of the product, including those that apply when the Yaskawa product is used in combination with other products.
- The customer must confirm that the Yaskawa product is suitable for the customer's plant, machinery and equipment.
- If the Yaskawa product is used in a manner not specified by this manual, the protection provided by the Yaskawa product may be impaired and the use may result in material or immaterial damage.
- Contact Yaskawa to determine whether use is permitted in the following applications. If the use in the respective application is permissible, the Yaskawa product is to be used by considering additional risk assessments and specifications, and safety measures are to be provided to minimise the dangers in the event of a fault. Special caution is required and protective measures must be taken in the case of:
 - Outdoor use, use with possible chemical contamination or electrical interference, or use under conditions or in environments which are not described in product catalogs or manuals
 - Nuclear control systems, combustion systems, railway systems, aviation systems, automotive systems, medical devices, amusement machines and equipment that is specifically regulated by industry or government
 - Systems, machines and devices that can pose a risk to life or property
 - Systems that require a high degree of reliability, such as gas, water or electricity supply systems or systems that operate 24 hours a day
 - Other systems that require a similarly high level of security
- Never use the Yaskawa product in an application where failure of the product could cause serious danger to life, limb, health or property without first ensuring that the system is designed to provide the required level of safety with risk warnings and redundancy to avoid the realisation of such dangers and that the Yaskawa product is properly designed and installed.
- The connection examples and other application examples described in the product catalogs and manuals of Yaskawa are for reference purposes. Check the functionality and safety of the devices and systems actually to be used before using the Yaskawa product.
- To avoid accidental harm to third parties, read and understand all prohibitions on use and precautions, and operate the Yaskawa product correctly.

Field of application

- The Yaskawa product is not suited for use in life-support machines or systems.
- Please contact your Yaskawa representative or Yaskawa distributor if considering the use of the Yaskawa product for special purposes, such as machines or systems used in passenger cars, in medical, aircraft and aerospace applications, for power supply of networks, for electrical power distribution or for underwater applications.

**DANGER**

The device is not permitted for use

- in explosive environments (EX zone)

The system is designed and manufactured for proper use and use in accordance with the user manual and is designed for:

- Communication and process control
- general control and automation tasks
- for industrial use
- operation within the environmental conditions specified in the technical data
- installation in a cabinet

**DANGER**

If this Yaskawa product is used in applications where failure of the device can result in the loss of human life, a serious accident or physical injury, you must install appropriate safety devices.

- Death or serious injury can result if you do not install the safety devices properly.

Disclaimer

(1) The contractual and legal liability of Yaskawa and the legal representatives and vicarious agents of Yaskawa for compensation and reimbursement of expenses in relation to the content of this documentation is excluded or limited as follows:

a) For slightly negligent breaches of *Essential Contractual Duties* arising from the contractual obligation, for Yaskawa the amount of liability is limited to the foreseeable damage typical for the contract. '*Essential Contractual Duties*' are those duties that characterise the performance of the contract and on which the Yaskawa customer may reasonably rely.

(b) In each case, Yaskawa is not liable for (i) the slightly negligent breach of duties arising from the duties that are not *Essential Contractual Duties*, as well as (ii) force majeure, i.e. external events that have no operational connection and cannot be averted even by exercising the utmost care that can reasonably be expected.

(2) The aforementioned limitation of liability does not apply (i) in cases of mandatory statutory liability (in particular under the product liability law), (ii) if and to the extent that Yaskawa has assumed a guarantee or same as guaranteed procurement risk according to § 276 BGB, (iii) for culpably caused injuries to life, limb and/or health, also by representatives or vicarious agents, as well as (iv) in case of delay in the event of a fixed completion date.

(3) A reversal of the burden of proof is not associated with the provisions above.

Disposal

National rules and regulations apply to the disposal of the unit!

2 Basics and mounting

2.1 Safety notes for the user



DANGER

Protection against dangerous voltages

- When using System MICRO modules, the user must be protected from touching hazardous voltage.
- You must therefore create an insulation concept for your system that includes safe separation of the potential areas of ELV and hazardous voltage.
- Here, observe the insulation voltages between the potential areas specified for the System MICRO modules and take suitable measures, such as using PELV/SELV power supplies for System MICRO modules.

Handling of electrostatic sensitive modules

The modules are equipped with highly integrated components in MOS technology. These components are highly sensitive to over-voltages that occur, e.g. with electrostatic discharge. The following symbol is used to identify these hazardous modules:



The symbol is located on modules, module racks or on packaging and thus indicates electrostatic sensitive modules. Electrostatic sensitive modules can be destroyed by energies and voltages that are far below the limits of human perception. If a person who is not electrically discharged handles electrostatic sensitive modules, voltages can occur and damage components and thus impair the functionality of the modules or render the modules unusable. Modules damaged in this way are in most cases not immediately recognized as faulty. The error can only appear after a long period of operation. Components damaged by static discharge can show temporary faults when exposed to temperature changes, vibrations or load changes. Only the consistent use of protective devices and responsible observance of the handling rules can effectively prevent malfunctions and failures on electrostatic sensitive modules.

Shipping of modules

Please always use the original packaging for shipping.

Measurement and modification of electrostatic sensitive modules

For measurements on electrostatic sensitive modules the following must be observed:

- Floating measuring instruments must be discharged before use.
- Measuring instruments used must be grounded.

When modifying electrostatic sensitive modules, ensure that a grounded soldering iron is used.



CAUTION

When working with and on electrostatic sensitive modules, make sure that personnel and equipment are adequately grounded.

2.2 System conception

Overview

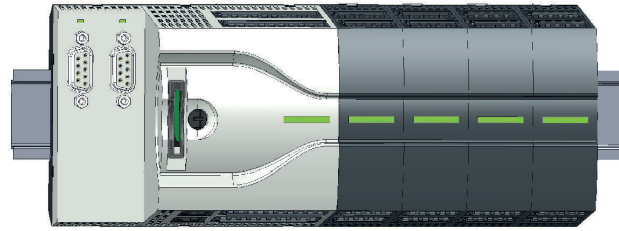

The System MICRO is a modular automation system for assembly on a 35mm profile rail. By means of periphery modules this system may be adapted matching to your automation tasks. In addition, it is possible to expand your CPU by appropriate interfaces. The wiring complexity is low, because the DC 24V electronic section supply is integrated to the backplane bus and this allows replacement with standing wire.

Components

- CPU
- Extension module
- Power supply
- Periphery module

CPU

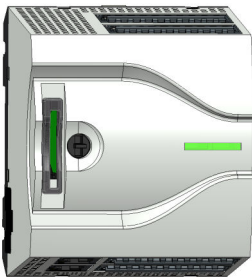

With the CPU electronic, input/output components and power supply are integrated to one casing. In addition, up to 8 periphery modules of the System MICRO can be connected to the backplane bus. As head module via the integrated power module for power supply CPU electronic and the I/O components are supplied as well as the electronic of the periphery modules, which are connected via backplane bus. To connect the power supply of the I/O components and for DC 24V electronic power supply of the periphery modules, which are connected via backplane bus, the CPU has removable connectors. By installing of up to 8 periphery modules at the backplane bus of the CPU, these are electrically connected, this means these are assigned to the backplane bus and connected to the DC 24V electronic power supply.

Extension module



By using extension modules you can extend the interfaces of the CPU. The attachment to the CPU is made by plugging on the left side of the CPU. You can only connect one extension module to the CPU at a time.

Power supply



The power supply is mounted on the left side of the profile rail with the System MICRO modules. It serves for electronics and power supply.

Periphery module



By means of up to 8 periphery modules, you can extend the internal I/O areas. The attachment to the CPU is made by plugging them on the right side of the CPU.

Profile rail



Order no.	Description
290-1AF00	35 mm profile rail length 2000mm
290-1AF30	35 mm profile rail length 530mm



NOTICE

To ensure EMC, the profile rail must be grounded!



- Ensure that the profile rail is reliably and professionally grounded.
- By mounting them on the grounded profile rail, the modules are automatically connected to the grounding system.

[‘Grounding guidelines’...page 14](#)

[‘Installation guidelines’...page 34](#)

Spare parts

The following spare parts are available for the System MICRO:

Spare part	Order no.	Description	Packaging unit
	M92-9BC00	5-fold connector for System MICRO module.	5 pieces
	M92-9BH00	10-fold connector for System MICRO CPU.	5 pieces



CAUTION

Please note that you may only use the spare parts with Yaskawa modules. Use with third-party modules is not allowed!

Dimensions

2.3 Dimensions

Dimensions CPU M13C

All dimensions are in mm.

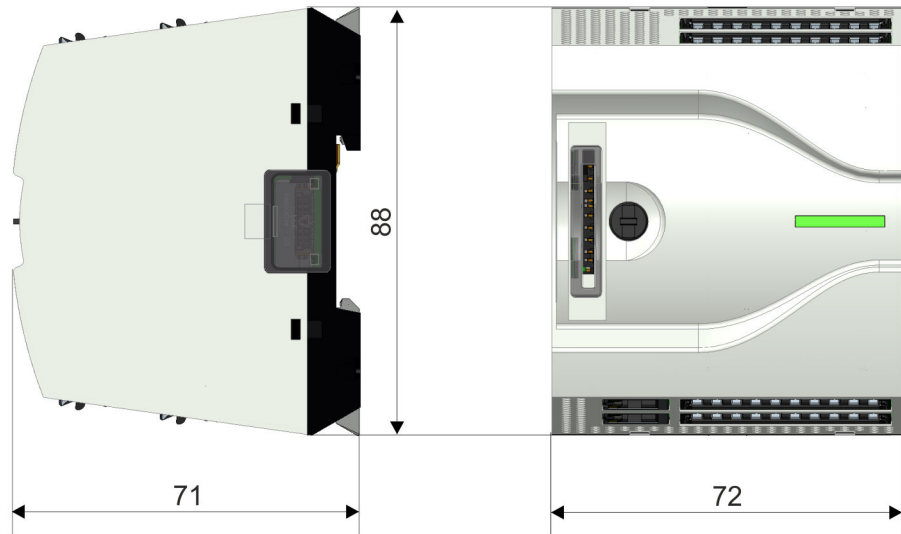

Dimensions extension module EM M09

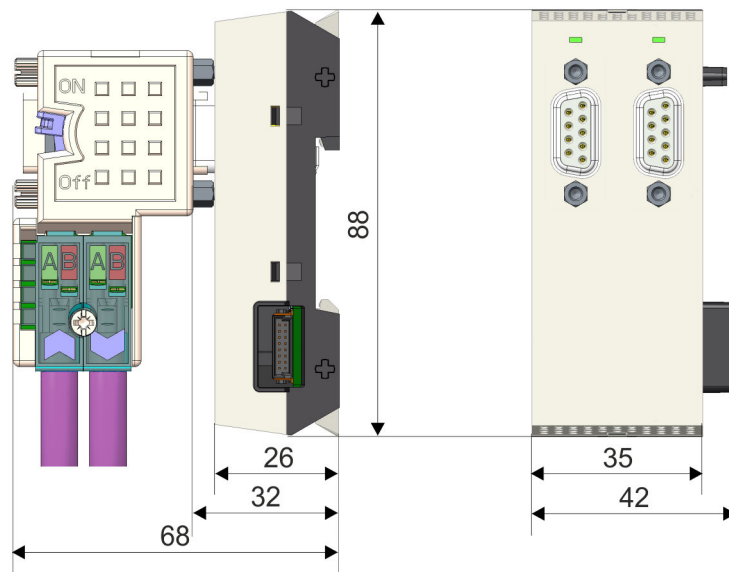

Dimensions power supply

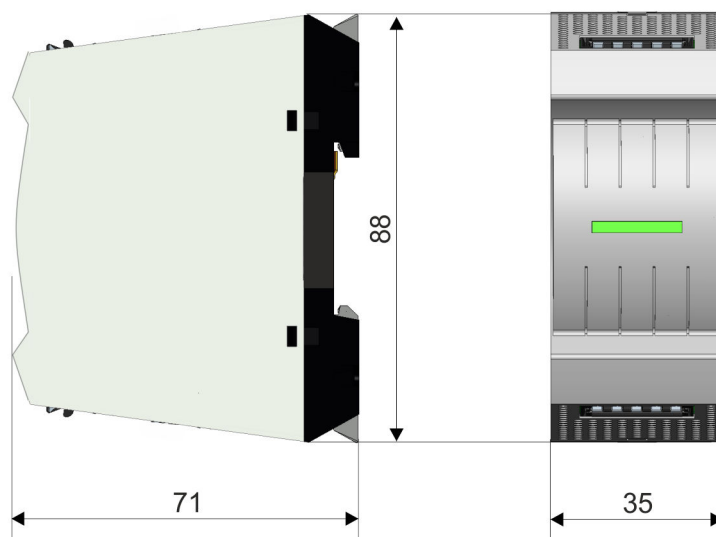

Dimensions periphery module

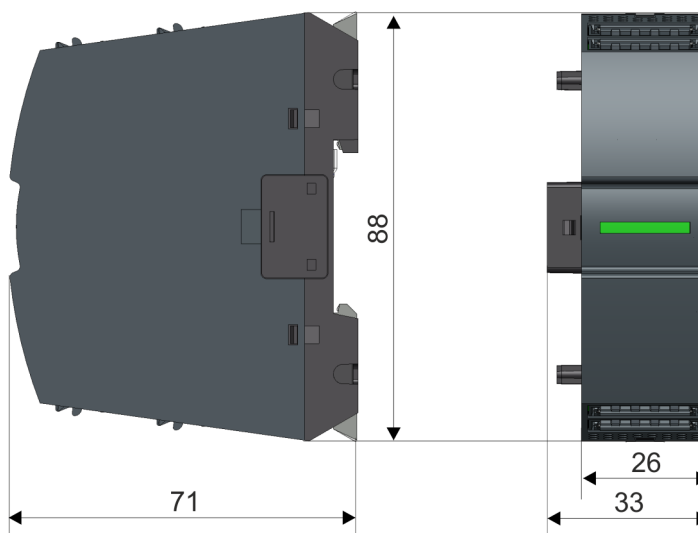

2.4 Grounding concept

Grounding guidelines

For reliable grounding, ensure that all common ground connections and the functional earth (FE) of your System MICRO and all connected devices are connected to a central point and grounded there.



NOTICE

To ensure EMC, the profile rail must be grounded!

- Ensure that the profile rail is reliably and professionally grounded.
- By mounting them on the grounded profile rail, the modules are automatically connected to the grounding system.

'Installation guidelines'...page 34

- To avoid potential differences, use grounding cables that are as short as possible and have a large cross-section.
- When selecting grounding points, observe the applicable safety regulations.
- When assembling your components, ensure that the inactive metal parts are properly grounded over a large area.
 - Connect all inactive metal parts over a large area and with low impedance.
 - Avoid using aluminium parts if possible. Aluminium is easily oxidizing and is therefore less suitable for grounding.

2.4.1 Shielding

Overview

Shielding of the Signal lines is required for interference-free signal transmission of analog signals and counter pulses. This weakens electrical, magnetic or electromagnetic interference fields.

- Shielded cables must be placed directly below the module on the shield bus to be provided for this purpose.
- The shield bus must be connected locally to the base plate with low impedance.
- The shield rail must be screwed to the base plate by means of appropriate shield bus holders. Ensure a good conductive connection between the shield bus and the base plate.
- The shield bus holders are available with an internal connection for electrical contacting between the base plate and the shield bus, or in an insulated version.
- The shields of external cables must be connected to ground/earth at the control cabinet entry.

'Installation guidelines'...page 34



CAUTION

Improper shielding can lead to increased EMC radiation.

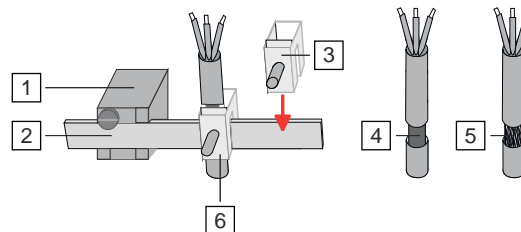

- 1 Shield bus holder
- 2 Shield bus (10mm x 3mm)
- 3 Shield clamp
- 4 Cable shield with metal foil
- 5 Cable shield with wire mesh (close-meshed)
- 6 Cable shield mounted with shield clamp

Shield attachment

1. → Mount the shield bus holders on the base plate so that the shield bus can be placed as close as possible to the System MICRO modules.
2. → Place your shield bus into the shield bus holder and fix it.

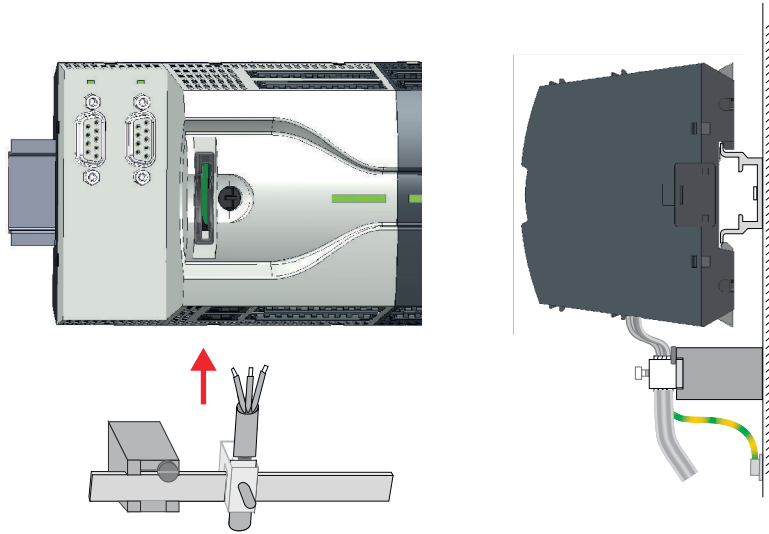

3. → Attach the cables with the accordingly stripped cable screen and fix it by the shield clamp with the shield bus.
4. → The shield bus must always be earthed. Keep all cable connections as short as possible. To earth the shield bus, connect a PE conductor to the shield bus via a shield clamp and screw it to the base plate as close as possible and with low impedance.

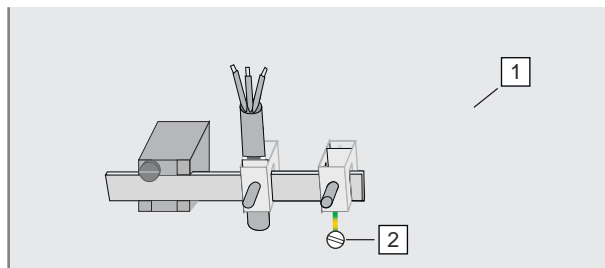

- 1 Base plate
- 2 PE conductor screwed to base plate

2.5 Mounting



CAUTION

Requirements for UL compliance use

- Use for power supply exclusively SELV/PELV power supplies.

2.5.1 Mounting CPU

2.5.1.1 Mounting CPU without profile rail



CAUTION

Mounting without profile rail is only permitted, if you only want to use the CPU without extension and periphery modules. Otherwise, a profile rail must always be used for EMC technical reasons.

Proceeding

To fulfil the EMC specifications, the System MICRO may only be operated in a metal switch cabinet with a metal base plate. You can screw the CPU to the back wall by means of screws via the locking levers. This happens with the following proceeding:

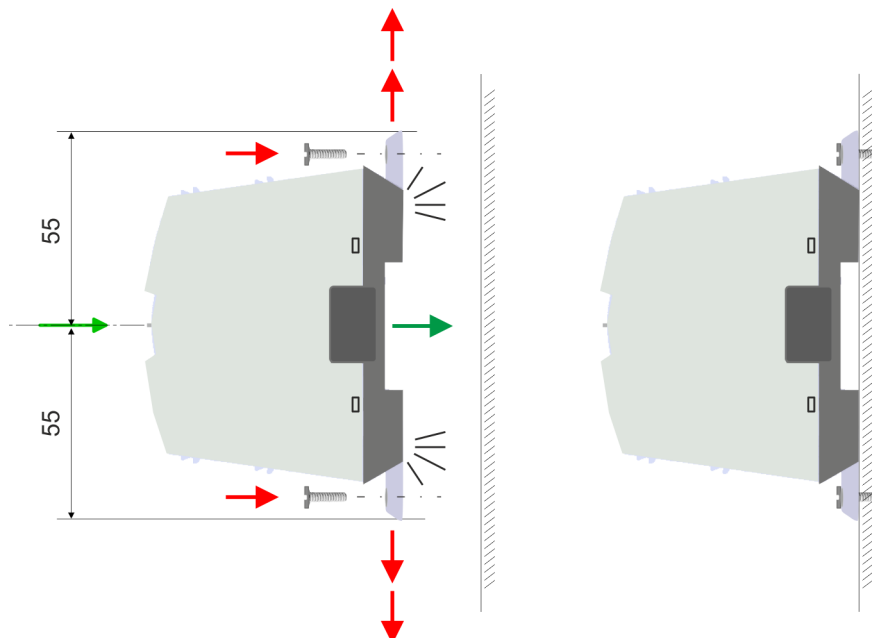

Dimensions in mm

1. The CPU has a locking lever on the upper and lower side. Pull these levers outwards as shown in the figure, until these engage 2x audible.
 - ➔ By this openings on the locking levers get visible.
2. Use the appropriate screws to fix your CPU to your back wall. Consider the installation clearances for the CPU.
 - ➔ The CPU is now mounted and can be wired.

2.5.1.2 Mounting with profile rail

Proceeding

To fulfil the EMC specifications, the System MICRO may only be operated in a metal switch cabinet with a metal base plate.

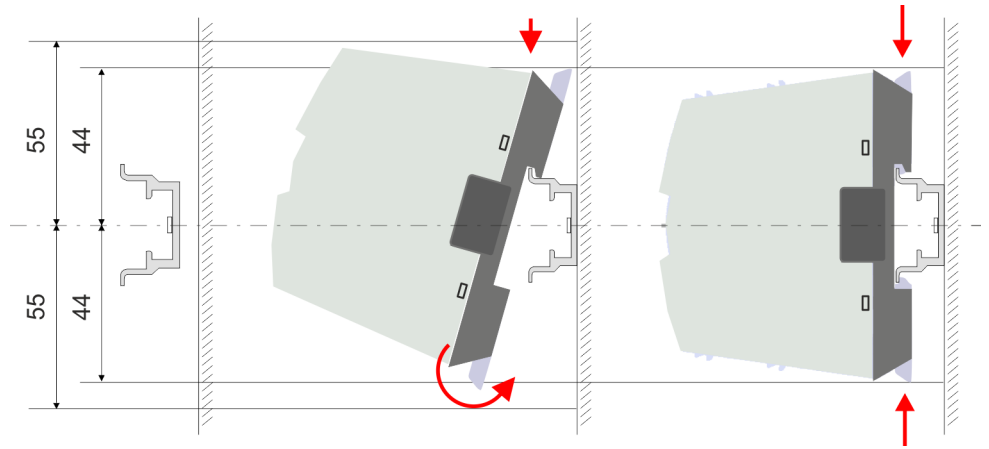

Dimensions in mm

1. → Mount the profile rail. Please consider that a clearance from the middle of the profile rail of at least 44mm respectively 55mm above and below exists.
2. → The CPU has a locking lever on the upper and lower side. Pull these levers outwards as shown in the figure, until these engage audible.



CAUTION

It is not allowed to mount the module sideways on the profile rail, as otherwise the module may be damaged.

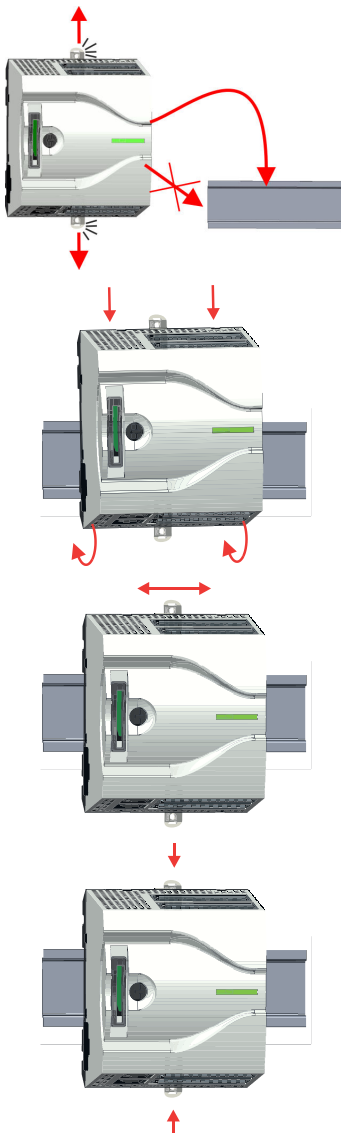

3. → Plug the CPU from the top onto the profile rail and turn the CPU downward until it rests on the profile rail.
4. → Move the CPU on the profile rail at its position.
5. → To fix the CPU at the profile rail, move the locking levers back to the initial position.
 - ➔ The CPU is now mounted and can be wired.

2.5.2 Mounting the extension module

Proceeding

You have the possibility to extend the interfaces of the CPU by plugging an extension module. For this the extension module is plugged at the left side of the CPU. The mounting happens with the following proceeding:

1. → Remove the bus cover with a screwdriver on the left side of the CPU.

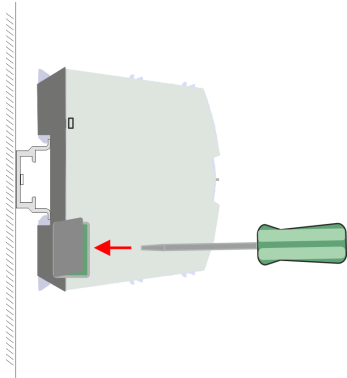

2. → The extension module has a locking lever on the upper and lower side. Pull these levers outwards as shown in the figure, until these engage audible.



CAUTION

It is not allowed to mount the module sideways on the profile rail, as otherwise the module may be damaged.

3. → To mount plug the extension module from the top onto the profile rail and turn the extension module downward until it rests on the profile rail.

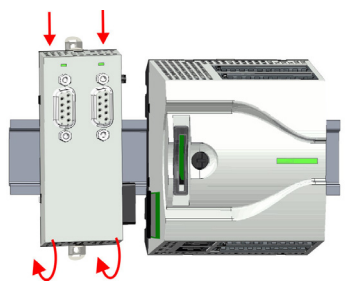
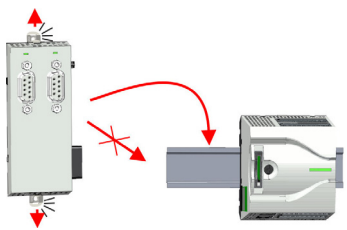

4. → Attach the extension module to the CPU by sliding the extension module on the profile rail to the right until the interface connector slightly locks into the CPU.

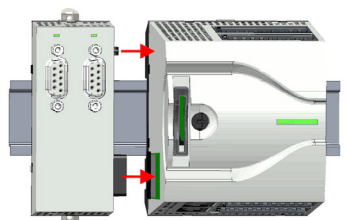

5. → To fix the extension module at the profile rail, move the locking levers back to the initial position.

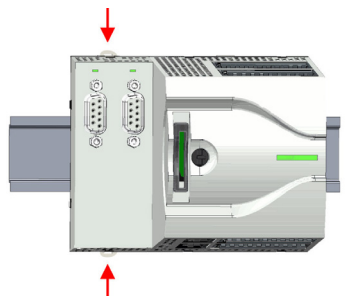

2.5.3 Mounting periphery module

Proceeding

You have the possibility to extend the periphery area of the CPU by plugging up to 8 periphery modules. For this the periphery modules are plugged at the right side of the CPU. The mountings happens with the following proceeding:

1. → Remove the bus cover with a screwdriver on the right side of the CPU.

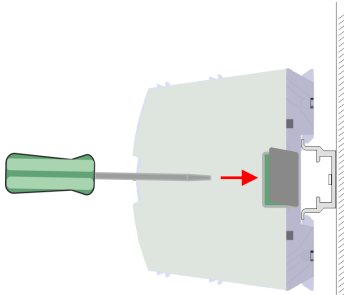

2. → Each periphery module has a locking lever on its upper and lower side. Pull these levers outwards as shown in the figure, until these engage audible.

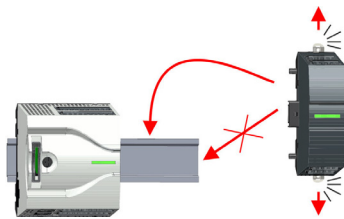

CAUTION

It is not allowed to mount the module sideways on the profile rail, as otherwise the module may be damaged.

3. → To mount plug the periphery module from the top onto the profile rail and turn the periphery module downward until it rests on the profile rail.

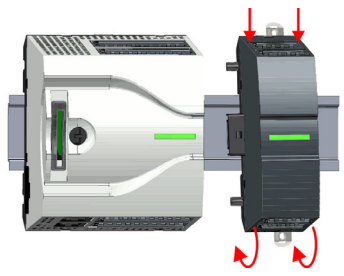

4. → Attach the periphery module to the CPU by sliding the periphery module on the profile rail to the left until the interface connector slightly locks into the CPU.

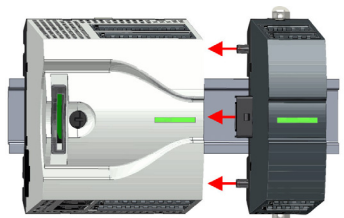

5. → To fix the periphery module at the profile rail, move the locking levers back to the initial position.

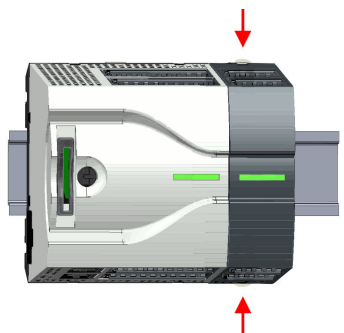

6. → Proceed in this way with additional periphery modules.

2.6 Wiring

Notes and guidelines



DANGER

Consider strain relief of the supply lines!

Since the plug for the supply lines of the input voltage has no (double) insulation, not permanently fixed supply lines must be relieved from push and pull!



CAUTION

Consider temperature for external cables!

Cables may experience temperature increase due to system heat dissipation. Thus the cabling specification must be chosen 25°C above ambient temperature!



CAUTION

Separate insulation areas!

The system is specified for SELV/PELV environment. Devices, which are attached to the system must meet these specifications. Installation and cable routing other than SELV/PELV specification must be separated from the system's equipment!

2.6.1 Wiring CPU

CPU connector

For wiring the CPU has removable connectors. With the wiring of the connectors a "push-in" spring-clip technique is used. This allows a quick and easy connection of your signal and supply lines. The clamping off takes place by means of a screwdriver with 2.5mm blade width.

Data

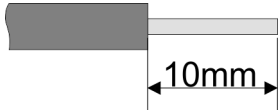

Please use copper wire only!

U _{max}	30V DC
I _{max}	10A
Cross section	0.2 ... 1.5mm ² (AWG 24 ... 16)
Stripping length	10mm

Shield attachment

'Shielding'...page 14

Wiring procedure

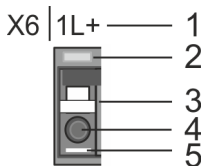

→ Determine according to the casing labelling the connection position.

- 1 Labeling on the casing
- 2 Status LED
- 3 Release area
- 4 Connection hole for wire
- 5 Pin 1 of the connector is labelled by a white line

Insert wire

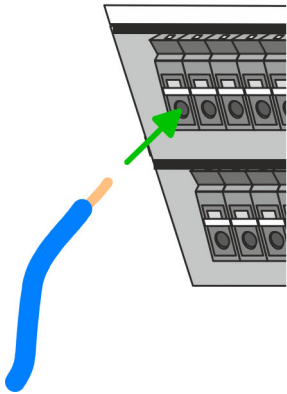

- ➔ Insert through the round connection hole of the according contact your prepared wire until it stops, so that it is fixed. When using stranded wires you have to press the release button with the screwdriver during the wiring.
- ➔ By pushing the contact spring opens, thus ensuring the necessary contact pressure.

Remove wire

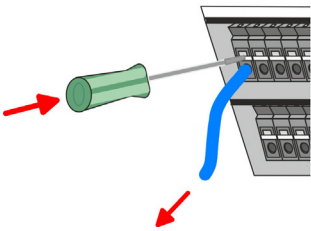

1. ➔ The wire is to be removed by means of the screwdriver. Press with your screwdriver vertically at the release button.
- ➔ The contact spring releases the wire.
2. ➔ Pull the wire from the round hole.

Standard wiring

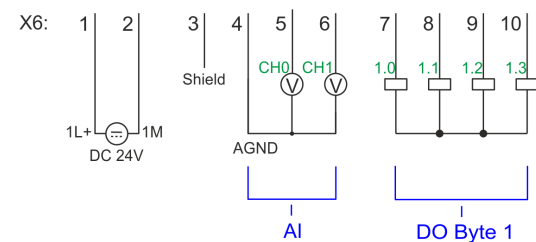
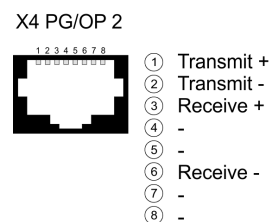
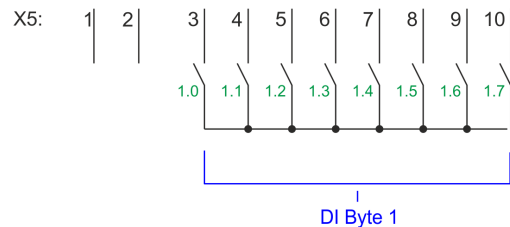
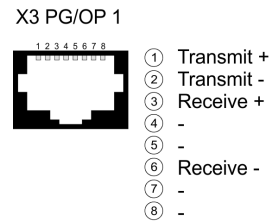
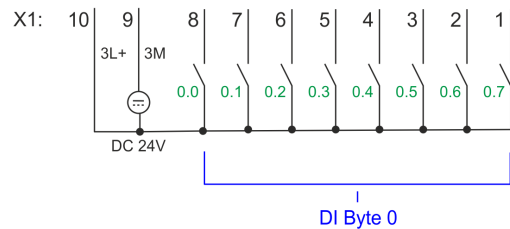
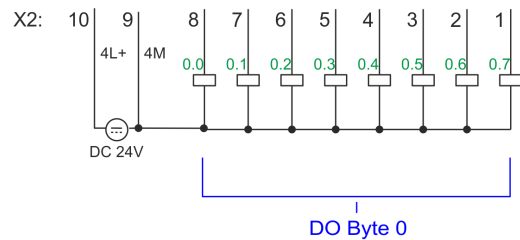
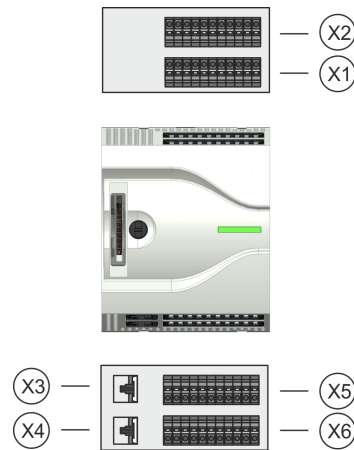

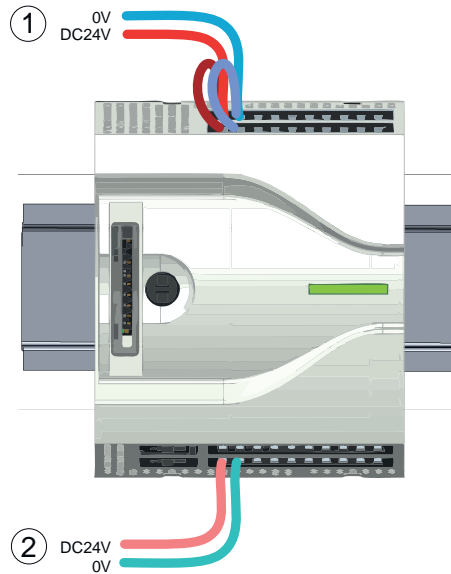

- (1) X2: 4L+: DC 24V power section supply for integrated outputs
X1: 3L+: DC 24V power section supply for integrated inputs
- (2) X6: 1L+ DC 24V for electronic power supply



The electronic power section supply is internally protected against higher voltage by fuse. The fuse is located inside the CPU and can not be changed by the user.

Fusing



CAUTION

- The power section supply of the internal DOs is to be externally protected with a 8A fuse (fast) respectively by a line circuit breaker 8A characteristics Z.

Remove connector

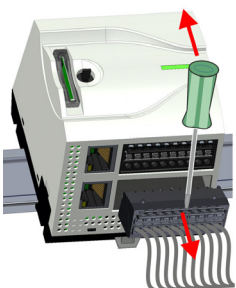
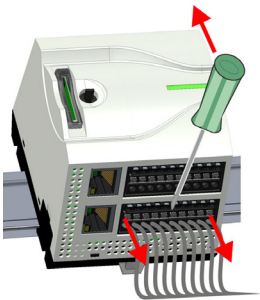

By means of a screwdriver there is the possibility to remove the connectors e.g. for module exchange with a fix wiring. For this each connector has indentations for unlocking at the top. Unlocking takes place by the following proceeding:

1. Remove connector:

Insert your screwdriver from above into one of the indentations.

2. Push the screwdriver backwards:

➔ The connector is unlocked and can be removed.



CAUTION

Via wrong operation such as pressing the screwdriver downward, the release lever may be damaged.

3. Plug connector:

The connector is plugged by plugging it directly into the release lever.

2.6.2 Wiring periphery module

Periphery module connector

For wiring the periphery module has removable connectors. With the wiring of the connectors a "push-in" spring-clip technique is used. This allows a quick and easy connection of your signal and supply lines. The clamping off takes place by means of a screwdriver with 2.5mm blade width.

Data

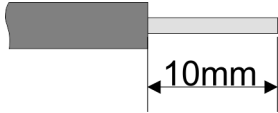

Please use copper wire only!

U_{max} 240V AC / 30V DC
 I_{max} 10A
 Cross section 0.2 ... 1.5mm² (AWG 24 ... 16)
 Stripping length 10mm

Shield attachment

[‘Shielding’...page 14](#)

Wiring procedure

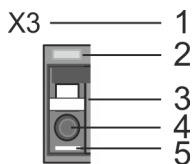

→ Determine according to the casing labelling the connection position.

- 1 Labeling on the casing
- 2 Status LED
- 3 Release area
- 4 Connection hole for wire
- 5 Pin 1 of the connector is labelled by a white line

Insert wire

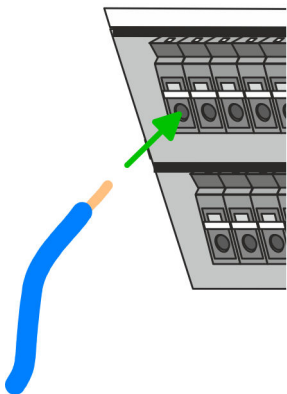

→ Insert through the round connection hole of the according contact your prepared wire until it stops, so that it is fixed. When using stranded wires you have to press the release button with the screwdriver during the wiring.

- ➔ By pushing the contact spring opens, thus ensuring the necessary contact pressure.

Remove wire

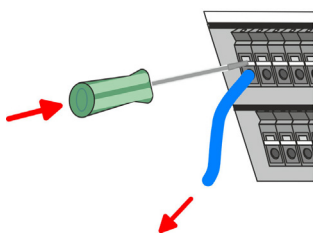

1. → The wire is to be removed by means of the screwdriver. Press with your screwdriver vertically at the release button.
 - ➔ The contact spring releases the wire.
2. → Pull the wire from the round hole.

Fusing



CAUTION

- The power section supply of the output modules DO16 is to be externally protected with a 10A fuse (fast) respectively by a line circuit breaker 10A characteristics Z.
- The power section supply of the output part of the DIO8 is to be externally protected with a 5A fuse (fast) respectively by a line circuit breaker 5A characteristics Z.

Remove connector

By means of a screwdriver there is the possibility to remove the connectors e.g. for module exchange with a fix wiring. For this each connector has indentations for unlocking at the top. Unlocking takes place by the following proceeding:

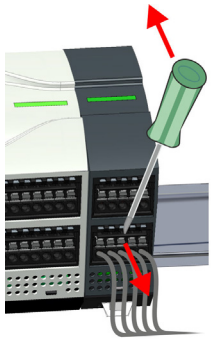

1. → Remove connector:

Insert your screwdriver from above into one of the indentations.

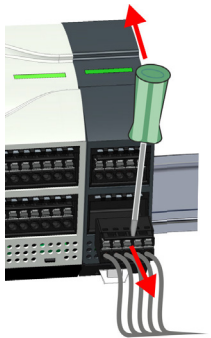

2. → Push the screwdriver backwards:

→ The connector is unlocked and can be removed.



CAUTION

Via wrong operation such as pressing the screwdriver downward, the release lever may be damaged.

3. → Plug connector:

The connector is plugged by plugging it directly into the release lever.

2.7 Demounting

2.7.1 Demounting CPU

Remove connector

By means of a screwdriver there is the possibility to remove the connectors e.g. for module exchange with a fix wiring. For this each connector has indentations for unlocking at the top. Unlocking takes place by the following proceeding:

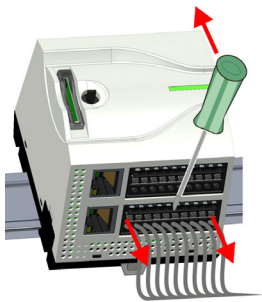

1. → Power-off your system.

2. → Remove connector:

Insert your screwdriver from above into one of the indentations.

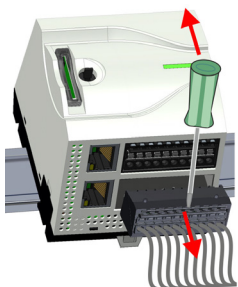

3. → Push the screwdriver backwards:

→ The connector is unlocked and can be removed.



CAUTION

Via wrong operation such as pressing the screwdriver downward, the connector may be damaged!

4. → In this way, remove all plugged connectors on the CPU.

CPU replacement (stand-alone)

If more modules are connected to the CPU 'Option: CPU replacement in a system'...page 26. If no other modules are connected to the CPU, the CPU is replaced according to the following proceeding:

1. Use a screwdriver to pull the locking levers of the CPU outwards until these engage audible.

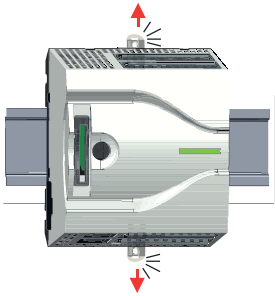

2. Remove the CPU with a rotation upwards from the profile rail.

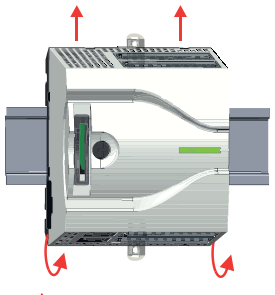

3. Pull the locking levers of the CPU outwards until these engage audible.

**CAUTION**

It is not allowed to mount the module sideways on the profile rail, as otherwise the module may be damaged!

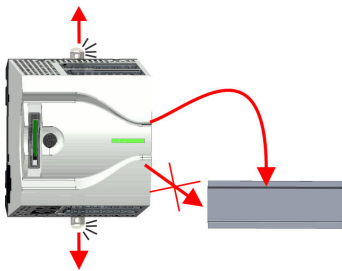

4. Plug the CPU from the top onto the profile rail and turn the CPU downward until it rests on the profile rail.

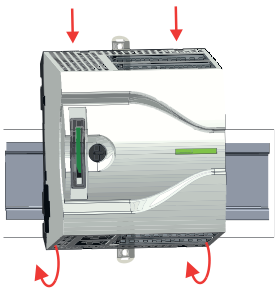

5. Move the CPU on the profile rail at its position.

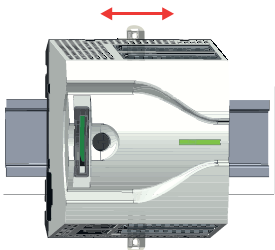

6. To fix the CPU at the profile rail, move the locking levers back to the initial position.

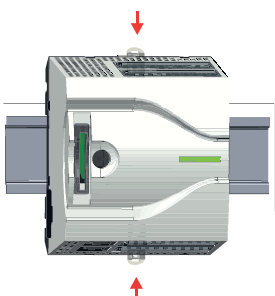

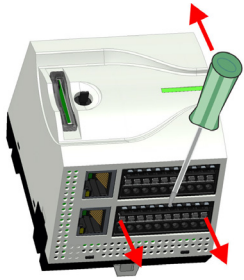

7. → Remove the connectors, which are not necessary at the CPU.

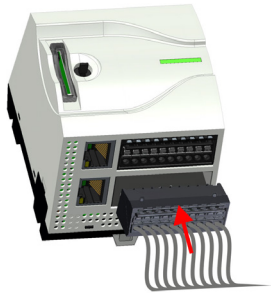

8. → Plug again the wired connectors.

➔ Now you can bring your system back into operation.

Option: CPU replacement in a system

In the following the replacement of a CPU in a system is shown:

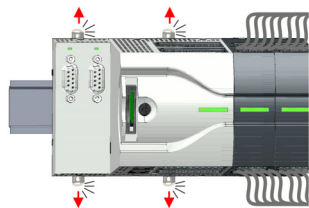

1. → If there is an extension module connected to the CPU, you have to remove it from the CPU. For this use a screwdriver to pull the locking levers of the extension module and CPU outwards until these engage audible.

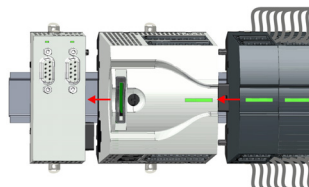

2. → Disconnect all the modules, which are connected to the CPU by moving the CPU along with the extension module on the profile rail.

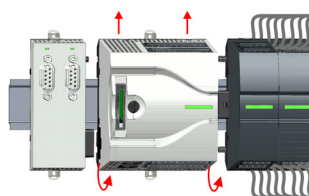

3. → Remove the CPU with a rotation upwards from the profile rail.

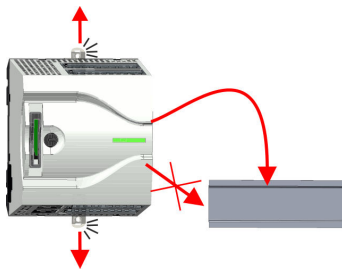

4. → Pull the locking levers of the CPU outwards until these engage audible.



CAUTION

It is not allowed to mount the module sideways on the profile rail, as otherwise the module may be damaged!

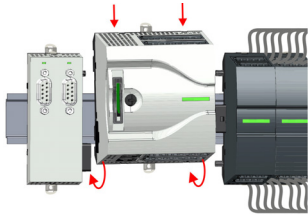

5. → For mounting pull the locking levers of the CPU outwards until these engage audible. Plug the CPU from the top onto the profile rail and turn the CPU downward until it rests on the profile rail.

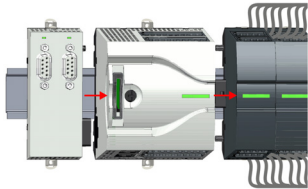

6. → Rebind your modules by moving the CPU along with the extension module on the profile rail.

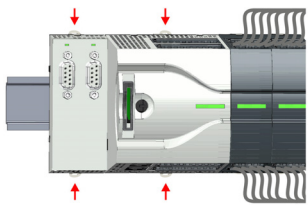

7. → To fix the CPU at the profile rail, move the locking levers back to the initial position.

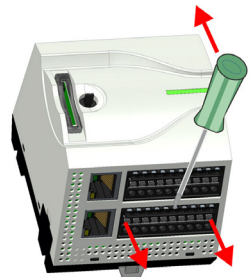

8. → Remove the connectors, which are not necessary at the CPU.

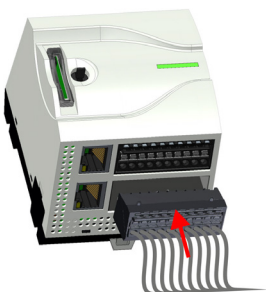

9. → Plug again the wired connectors.
→ Now you can bring your system back into operation.

2.7.2 Demounting the extension module

Proceeding

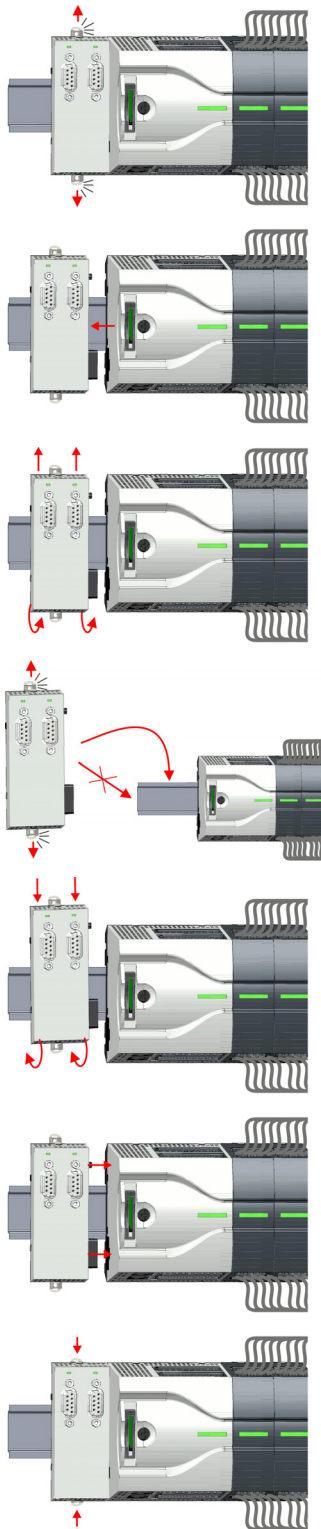

1. ➤ Power-off your system.
2. ➤ Remove the corresponding bus connectors.
3. ➤ Use a screwdriver to pull the locking levers of the extension module outwards until these engage audibly.

4. ➤ Remove the extension module from the CPU by sliding it on the profile rail.

5. ➤ Remove the extension module with a rotation upwards from the profile rail.

6. ➤ Pull the locking levers of the extension module outwards until these engage audibly.



CAUTION

It is not allowed to mount the module sideways on the profile rail, as otherwise the module may be damaged!

7. ➤ Plug the extension module from the top onto the profile rail and turn the extension module downward until it rests on the profile rail.

8. ➤ Reattach the extension module to the CPU by sliding the extension module on the profile rail to the right until the interface connector slightly locks into the CPU.

9. ➤ Move the locking levers back to the initial position.

10. ➤ Plug the corresponding bus connectors.
 - ➔ Now you can bring your system back into operation.

2.7.3 Demounting periphery module

Remove connector

By means of a screwdriver there is the possibility to remove the connectors e.g. for module exchange with a fix wiring. For this each connector has indentations for unlocking at the top. Unlocking takes place by the following proceeding:

1. → Power-off your system.



CAUTION

Make sure that the working contacts from the relay module are disconnected from the power supply!

2. → Remove connector:

Insert your screwdriver from above into one of the indentations.

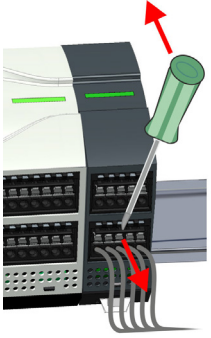

3. → Push the screwdriver backwards:

→ The connector is unlocked and can be removed.



CAUTION

Via wrong operation such as pressing the screwdriver downward, the connector may be damaged!



4. → In this way, remove all plugged connectors on the periphery module.

Replace the periphery module

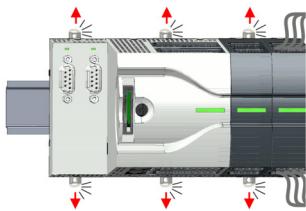

1. → Remove the modules that are connected to the module to be replaced by pulling their release levers outwards until these engage audible ...

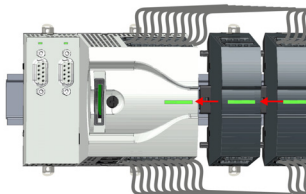

2. → ... and move the modules accordingly.

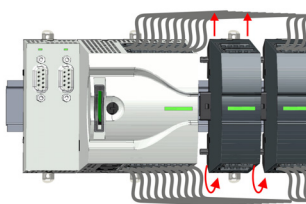

3. → Remove the periphery module with a rotation upwards from the profile rail.

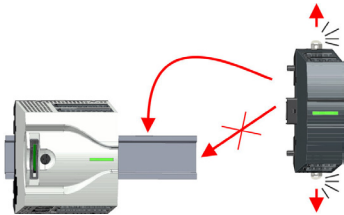

4. → Pull the locking levers outwards until these engage audible.



CAUTION

It is not allowed to mount the module sideways on the profile rail, as otherwise the module may be damaged!

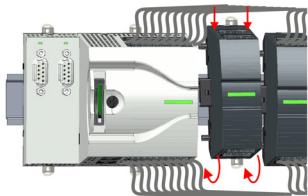

5. → Plug the periphery module from the top onto the profile rail and turn the periphery module downward until it rests on the profile rail.

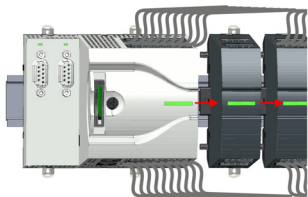

6. → Reconnect all modules by pushing them together again on the profile rail.

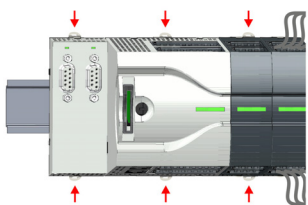

7. → Move the locking levers back to the initial position.



8. → Remove the connectors, which are not necessary.



9. → Plug again the wired connectors.
 ➔ Now you can bring your system back into operation.

2.7.3.1 Easy Maintenance

Overview

Easy Maintenance means the support for adding and removing modules during operation without having to restart the system. There are the following behaviors:

- Periphery module is removed
 - The CPU detects a module failure on the backplane bus.
 - Diagnostic message 'System MICRO bus failure' (0x39D0) is triggered.
 - OB 86 is called. If this is not available, the CPU switches to STOP otherwise it remains in RUN.
 - The red LED of the status bar of the CPU lights up.
 - The I/O data of all modules become invalid.
- Identical periphery module is plugged
 - The CPU detects the module return on the backplane bus.
 - The red LED of the status bar of the CPU gets off.
 - All green LEDs of the status bars of the peripheral modules get on and all the red LEDs of the status bars of the peripheral modules get off.
 - Diagnostic message 'System MICRO bus recovery' (0x38D0) is triggered.
 - OB 86 is called. If this is not available, the CPU switches to STOP otherwise it remains in RUN.
 - The I/O data of all modules become valid again.
- Wrong periphery module is plugged
 - The CPU detects the wrong module.
 - Diagnostic message 'System MICRO bus recovery, but expected configuration does not match actual configuration' (0x38D1) is triggered.
 - The red LED of the status bar of the CPU remains on.
 - The red LED of the status bar of the wrong I/O module flashes.
 - OB 86 is called. If this is not available, the CPU switches to STOP otherwise it remains in RUN.
 - With the exception of the wrong module, the I/O data of all modules become valid again.



Please note that the CPU switches to STOP, if there is no OB 86 configured when adding or removing System MICRO modules!

2.8 Industrial security and installation guidelines

2.8.1 Industrial security in information technology

Latest version

This chapter can also be found as a guide '*Industrial IT Security*' in the '*Download Center*' of www.yaskawa.eu.com

Hazards

The topic of data security and access protection has become increasingly important in the industrial environment. The increased networking of entire industrial systems to the network levels within the company together with the functions of remote maintenance have all served to increase vulnerability. Hazards can arise from:

- Internal manipulation such as technical errors, operating and program errors and deliberate program or data manipulation.
- External manipulation such as software viruses, worms and trojans.
- Human carelessness such as password phishing.

Precautions

The most important precautions to prevent manipulation and loss of data security in the industrial environment are:

- Encrypting the data traffic by means of certificates.
- Filtering and inspection of the traffic by means of VPN - "Virtual Private Networks".
- Identification of the user by "Authentication" via save channels.
- Segmenting in protected automation cells, so that only devices in the same group can exchange data.
- Deactivation of unnecessary hardware and software.

Further Information

You can find more information about the measures on the following websites:

- Federal Office for Information Technology → www.bsi.bund.de
- Cybersecurity & Infrastructure Security Agency → us-cert.cisa.gov
- VDI / VDE Society for Measurement and Automation Technology → www.vdi.de

2.8.1.1 Protection of hardware and applications

Precautions

- Do not integrate any components or systems into public networks.
 - Use VPN "Virtual Private Networks" for use in public networks. This allows you to control and filter the data traffic accordingly.
- Always keep your system up-to-date.
 - Always use the latest firmware version for all devices.
 - Update your user software regularly.
- Protect your systems with a firewall.
 - The firewall protects your infrastructure internally and externally.
 - This allows you to segment your network and isolate entire areas.
- Secure access to your plants via user accounts.
 - If possible, use a central user management system.
 - Create a user account for each user for whom authorization is essential.
 - Always keep user accounts up-to-date and deactivate unused user accounts.
- Secure access to your plants via secure passwords.
 - Change the password of a standard login after the first start.
 - Use strong passwords consisting of upper/lower case, numbers and special characters. The use of a password generator or manager is recommended.
 - Change the passwords according to the rules and guidelines that apply to your application.
- Deactivate inactive communication ports respectively protocols.
 - Only the communication ports that are used for communication should be activated.
 - Only the communication protocols that are used for communication should be activated.
- Consider possible defence strategies when planning and securing the system.
 - The isolation of components alone is not sufficient for comprehensive protection. An overall concept is to be drawn up here, which also provides defensive measures in the event of a cyber attack.
 - Periodically carry out threat assessments. Among others, a comparison is made here between the protective measures taken and those required.
- Limit the use of external storage media.
 - Via external storage media such as USB memory sticks or SD memory cards, malware can get directly into a system while bypassing a firewall.
 - External storage media or their slots must be protected against unauthorized physical access, e.g. by using a lockable control cabinet.
 - Make sure that only authorized persons have access.
 - When disposing of storage media, make sure that they are safely destroyed.
- Use secure access paths such as HTTPS or VPN for remote access to your plant.
- Enable security-related event logging in accordance with the applicable security policy and legal requirements for data protection.

2.8.1.2 Protection of PC-based software

Precautions

Since PC-based software is used for programming, configuration and monitoring, it can also be used to manipulate entire systems or individual components. Particular caution is required here!

- Use user accounts on your PC systems.
 - If possible, use a central user management system.
 - Create a user account for each user for whom authorization is essential.
 - Always keep user accounts up-to-date and deactivate unused user accounts.
- Protect your PC systems with secure passwords.
 - Change the password of a standard login after the first start.
 - Use strong passwords consisting of upper/lower case, numbers and special characters. The use of a password generator or manager is recommended.
 - Change the passwords according to the rules and guidelines that apply to your application.
- Enable security-related event logging in accordance with the applicable security policy and legal requirements for data protection.
- Protect your PC systems by security software.
 - Install virus scanners on your PC systems to identify viruses, trojans and other malware.
 - Install software that can detect phishing attacks and actively prevent them.
- Always keep your software up-to-date.
 - Update your operating system regularly.
 - Update your software regularly.
- Make regular backups and store the media at a safe place.
- Regularly restart your PC systems. Only boot from storage media that are protected against manipulation.
- Use encryption systems on your storage media.
- Perform security assessments regularly to reduce the risk of manipulation.
- Use only data and software from approved sources.
- Uninstall software which is not used.
- Disable unused services.
- Activate a password-protected screen lock on your PC systems.
- Always lock your PC systems as soon as you leave your PC workstation.
- Do not click any links that come from unknown sources. If necessary ask, e.g. on e-mails.
- Use secure access paths such as HTTPS or VPN for remote access to your PC system.

2.8.2 Installation guidelines

General

The installation guidelines contain information about the interference free deployment of a PLC system. There is the description of the ways, interference may occur in your PLC, how you can make sure the electromagnetic compatibility (EMC), and how you manage the isolation.

What does EMC mean?

Electromagnetic compatibility (EMC) means the ability of an electrical device, to function error free in an electromagnetic environment without being interfered respectively without interfering the environment.

The components are developed for the deployment in industrial environments and meets high demands on the EMC. Nevertheless you should project an EMC planning before installing the components and take conceivable interference causes into account.

Possible interference causes

Electromagnetic interferences may interfere your control via different ways:

- Electromagnetic fields (RF coupling)
- Magnetic fields with power frequency
- Bus system
- Power supply
- Protected ground conductor

Depending on the spreading medium (lead bound or lead free) and the distance to the interference cause, interferences to your control occur by means of different coupling mechanisms.

There are:

- galvanic coupling
- capacitive coupling
- inductive coupling
- radiant coupling

Basic rules for EMC

In the most times it is enough to take care of some elementary rules to guarantee the EMC. Please regard the following basic rules when installing your PLC.

- Take care of a correct area-wide grounding of the inactive metal parts when installing your components.
 - Connect all inactive metal extensive and impedance-low.
 - Please try not to use aluminium parts. Aluminium is easily oxidizing and is therefore less suitable for grounding.
- When cabling, take care of the correct line routing.
 - Organize your cabling in line groups (high voltage, current supply, signal and data lines).
 - Always lay your high voltage lines and signal respectively data lines in separate channels or bundles.
 - Route the signal and data lines as near as possible beside ground areas (e.g. suspension bars, metal rails, tin cabinet).
- Proof the correct fixing of the lead isolation.
 - Data lines must be shielded.
 - Analog lines must be shielded. When transmitting signals with small amplitudes the one sided laying of the isolation may be favourable.
 - Cables for frequency inverters, servo and stepper motors must be shielded.
 - Lay the line isolation extensively on an isolation/protected ground conductor rail directly after the cabinet entry and fix the isolation with cable clamps.
 - Make sure that the isolation/protected ground conductor rail is connected impedance-low with the cabinet.
 - Use metallic or metallised plug cases for isolated data lines.
- In special use cases you should appoint special EMC actions.
 - Consider to wire all inductivities with erase links.
 - Please consider luminescent lamps can influence signal lines.
- Create a homogeneous reference potential and ground all electrical operating supplies when possible.
 - Please take care for the targeted employment of the grounding actions. The grounding of the PLC serves for protection and functionality activity.
 - Connect installation parts and cabinets with your PLC in star topology with the isolation/protected ground conductor system. So you avoid ground loops.
 - If there are potential differences between installation parts and cabinets, lay sufficiently dimensioned potential compensation lines.

Isolation of conductors

Electrical, magnetically and electromagnetic interference fields are weakened by means of an isolation, one talks of absorption. Via the isolation rail, that is connected conductive with the rack, interference currents are shunt via cable isolation to the ground. Here you have to make sure, that the connection to the protected ground conductor is impedance-low, because otherwise the interference currents may appear as interference cause.

When isolating cables you have to regard the following:

- If possible, use only cables with isolation tangle.
- The hiding power of the isolation should be higher than 80%.
- Normally you should always lay the isolation of cables on both sides. Only by means of the both-sided connection of the isolation you achieve high quality interference suppression in the higher frequency area. Only as exception you may also lay the isolation one-sided. Then you only achieve the absorption of the lower frequencies. A one-sided isolation connection may be convenient, if:
 - the conduction of a potential compensating line is not possible.
 - analog signals (some mV respectively μA) are transferred.
 - foil isolations (static isolations) are used.
- With data lines always use metallic or metallised plugs for serial couplings. Fix the isolation of the data line at the plug rack. Do not lay the isolation on the PIN 1 of the plug bar!
- At stationary operation it is convenient to strip the insulated cable interruption free and lay it on the isolation/protected ground conductor line.
- To fix the isolation tangles use cable clamps out of metal. The clamps must clasp the isolation extensively and have well contact.
- Lay the isolation on an isolation rail directly after the entry of the cable in the cabinet.



CAUTION

Please regard at installation!

At potential differences between the grounding points, there may be a compensation current via the isolation connected at both sides.

Remedy: Potential compensation line

2.9 General data for the System MICRO

Conformity and approval		
Conformity		
CE	2014/35/EU	Low Voltage Directive
	2014/30/EU	EMC Directive
RoHS (EU)	2011/65/EU	Restriction of the use of certain hazardous substances in electrical and electronic equipment
UKCA	2016 No. 1101	Electrical Equipment (Safety) Regulations
	2016 No. 1091	Electromagnetic Compatibility Regulations
RoHS (UK)	2012 No. 3032	Use of Certain Hazardous Substances
Approval		
UL	-	Refer to Technical data

Protection of persons and device protection		
Type of protection	-	IP20
Electrical isolation		
to the field bus	-	electrically isolated
to the process level	-	electrically isolated
Insulation resistance	-	-
Insulation voltage to reference earth		
Inputs / outputs	-	AC / DC 50V, test voltage AC 500V
Protective measures	-	against short circuit

Environmental conditions to EN 61131-2		
Climatic		
Storage / transport	EN 60068-2-14	-25...+70°C
Operation		
Horizontal installation hanging	EN 61131-2	0...+60°C
Horizontal installation lying	EN 61131-2	0...+60°C
Vertical installation	EN 61131-2	0...+60°C
Air humidity	EN 60068-2-30	RH1 (without condensation, rel. humidity 10...95%)
Pollution	EN 61131-2	Degree of pollution 2
Installation altitude max.	-	2000m
Mechanical		
Oscillation	EN 60068-2-6	1g, 9Hz ... 150Hz
Shock	EN 60068-2-27	15g, 11ms

Mounting conditions		
Mounting place	-	In the control cabinet
Mounting position	-	Horizontal and vertical

EMC	Standard	Comment
Emitted interference	EN 61000-6-4	Class A (Industrial area)
Noise immunity zone B	EN 61000-6-2	Industrial area
		EN 61000-4-2
	EN 61000-4-3	HF field immunity (casing) 80MHz ... 1000MHz, 10V/m, 80% AM (1kHz) 1.4GHz ... 2.0GHz, 3V/m, 80% AM (1kHz) 2GHz ... 2.7GHz, 1V/m, 80% AM (1kHz)

General data for the System MICRO > Use in difficult operating conditions

EMC	Standard	Comment
	EN 61000-4-6	HF conducted 150kHz ... 80MHz, 10V, 80% AM (1kHz)
	EN 61000-4-4	Burst
	EN 61000-4-5	Surge ¹

1) Due to the high-energetic single pulses with Surge an appropriate external protective circuit with lightning protection elements like conductors for lightning and overvoltage is necessary.

2.9.1 Use in difficult operating conditions



Without additional protective measures, the products must not be used in locations with difficult operating conditions; e.g. due to:

- dust generation
- chemically active substances (corrosive vapors or gases)
- strong electric or magnetic fields

3 Digital in-/output

3.1 M21-1BH00 - DI 16xDC 24V

Properties

The module detects the binary control signals from the process level and transmits them isolated to the higher-level bus system. It has 16 channels and their status is indicated by LEDs.

- 16 digital Inputs isolated to the backplane bus
- Suitable for switches and proximity switches
- Status indication of the channels via LEDs

Structure

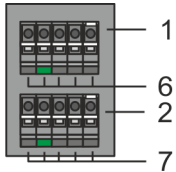

- 1 X2: Connector DI +0.4 ... +0.7
- 2 X1: Connector DI +0.0 ... +0.3
- 3 Status bar periphery module
- 4 X3: Connector DI +1.0 ... +1.3
- 5 X4: Connector DI +1.4 ... +1.7
- 6 X2: LEDs DI +0.4 ... +0.7
- 7 X1: LEDs DI +0.0 ... +0.3
- 8 X3: LEDs DI +1.0 ... +1.3
- 9 X4: LEDs DI +1.4 ... +1.7

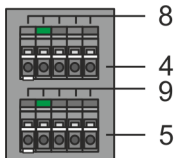
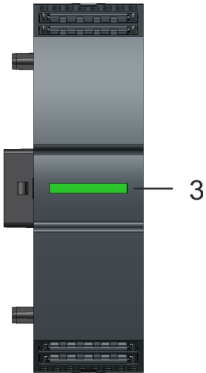

Status bar

LED	Description
	LEDs green on: Backplane bus communication and module status are OK
	LED red on: Module reports an error
	LED red blinks with 1Hz: Error in configuration
	LEDs green are blinking with 1Hz: Error backplane bus communication

M21-1BH00 - DI 16xDC 24V

LEDs connectors

Digital input	LED	Description
DI +0.0 DI +0.7	<input checked="" type="checkbox"/> green	Digital I+0.0 ... 0.7 has "1" signal
	<input type="checkbox"/>	Digital I+0.0 ... 0.7 has "0" signal
DI +1.0 ... DI +1.7	<input checked="" type="checkbox"/> green	Digital input I+1.0 ... 1.7 has "1" signal
	<input type="checkbox"/>	Digital input I+1.0 ... 1.7 has "0" signal

Pin assignment

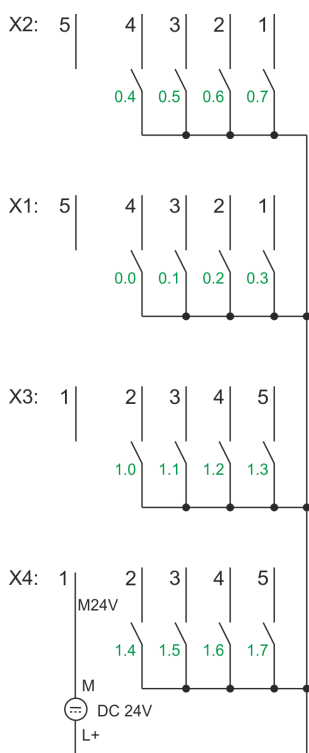

X	Pin	Function	Type	LED	Description
X2:	1	+0.7	I	<input checked="" type="checkbox"/> green	Digital input DI 7
	2	+0.6	I	<input checked="" type="checkbox"/> green	Digital input DI 6
	3	+0.5	I	<input checked="" type="checkbox"/> green	Digital input DI 5
	4	+0.4	I	<input checked="" type="checkbox"/> green	Digital input DI 4
	5	-	-		reserved
X1:	1	+0.3	I	<input checked="" type="checkbox"/> green	Digital input DI 3
	2	+0.2	I	<input checked="" type="checkbox"/> green	Digital input DI 2
	3	+0.1	I	<input checked="" type="checkbox"/> green	Digital input DI 1
	4	+0.0	I	<input checked="" type="checkbox"/> green	Digital input DI 0
	5	-	-		reserved
X3:	1	-	-		reserved
	2	+1.0	I	<input checked="" type="checkbox"/> green	Digital input DI 8
	3	+1.1	I	<input checked="" type="checkbox"/> green	Digital input DI 9
	4	+1.2	I	<input checked="" type="checkbox"/> green	Digital input DI 10
	5	+1.3	I	<input checked="" type="checkbox"/> green	Digital input DI 11
X4:	1	0V	I		Ground DI
	2	+1.4	I	<input checked="" type="checkbox"/> green	Digital input DI 12
	3	+1.5	I	<input checked="" type="checkbox"/> green	Digital input DI 13
	4	+1.6	I	<input checked="" type="checkbox"/> green	Digital input DI 14
	5	+1.7	I	<input checked="" type="checkbox"/> green	Digital input DI 15

I: Input

Input area

At the CPU the input area is embedded to the corresponding address area.

Addr.	Name	Byte	Function
+0	PII	0	Status of the inputs <ul style="list-style-type: none"> ■ Bit 0: DI 0 ■ Bit 1: DI 1 ■ Bit 2: DI 2 ■ Bit 3: DI 3 ■ Bit 4: DI 4 ■ Bit 5: DI 5 ■ Bit 6: DI 6 ■ Bit 7: DI 7
		1	Status of the inputs <ul style="list-style-type: none"> ■ Bit 0: DI 8 ■ Bit 1: DI 9 ■ Bit 2: DI 10 ■ Bit 3: DI 11 ■ Bit 4: DI 12 ■ Bit 5: DI 13 ■ Bit 6: DI 14 ■ Bit 7: DI 15

Output area

No byte of the output area is used by the module.

3.1.1 Technical data

Order no.	M21-1BH00
Type	SM M21 - Digital input
Module ID	0014 9FC2
Current consumption/power loss	
Current consumption from backplane bus	65 mA
Power loss	0.9 W
Technical data digital inputs	
Number of inputs	16
Cable length, shielded	1000 m
Cable length, unshielded	600 m
Rated load voltage	-
Current consumption from load voltage L+ (without load)	25 mA
Rated value	DC 20.4...28.8 V
Input voltage for signal "0"	DC 0...5 V
Input voltage for signal "1"	DC 15...28.8 V
Input voltage hysteresis	-
Signal logic input	Sinking input
Frequency range	-
Input resistance	-
Input capacitance	-
Input current for signal "1"	3 mA
Connection of Two-Wire-BEROs possible	✓
Max. permissible BERO quiescent current	0.5 mA
Input delay of "0" to "1"	3 ms
Input delay of "1" to "0"	3 ms
Number of simultaneously utilizable inputs horizontal configuration	16
Number of simultaneously utilizable inputs vertical configuration	16
Input characteristic curve	IEC 61131-2, type 1
Initial data size	16 Bit
Status information, alarms, diagnostics	
Status display	green LED per channel
Interrupts	no
Process alarm	no
Diagnostic interrupt	no
Diagnostic functions	no
Diagnostics information read-out	none

Order no.	M21-1BH00
Module state	none
Module error display	red LED
Channel error display	none
Isolation	
Between channels	-
Between channels of groups to	-
Between channels and backplane bus	✓
Insulation tested with	DC 500 V
Datasizes	
Input bytes	2
Output bytes	0
Parameter bytes	0
Diagnostic bytes	0
Housing	
Material	PPE / PPE GF10
Mounting	Profile rail 35 mm
Mechanical data	
Dimensions (WxHxD)	26 mm x 88 mm x 71 mm
Net weight	91 g
Weight including accessories	91 g
Gross weight	104 g
Environmental conditions	
Operating temperature	0 °C to 60 °C
Storage temperature	-25 °C to 70 °C
Certifications	
UL certification	yes
KC certification	yes
UKCA certification	yes
ChinaRoHS certification	yes

M22-1BH00 - DO 16xDC 24V 0.5A

3.2 M22-1BH00 - DO 16xDC 24V 0.5A

Properties

The module detects the binary control signals from the higher-level bus system and transports them to the process level via the outputs. It has 16 channels and their status is indicated by LEDs.

- 16 digital outputs isolated to the backplane bus
- Status indication of the channels via LEDs
- Diagnostic function can be parametrized in case of overload

Structure

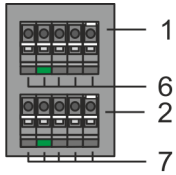



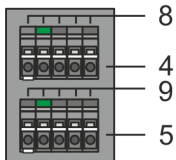
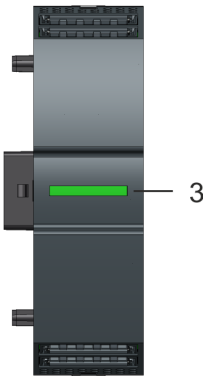

- 1 X2: Terminal DO +0.4 ... +0.7
- 2 X1: Terminal DO +0.0 ... +0.3
- 3 Status bar periphery module
- 4 X3: Terminal DO +1.0 ... +1.3
- 5 X4: Terminal DO +1.4 ... +1.7
- 6 X2: LEDs DO +0.4 ... +0.7
- 7 X1: LEDs DO +0.0 ... +0.3
- 8 X3: LEDs DO +1.0 ... +1.3
- 9 X4: LEDs DO +1.4 ... +1.7



Status bar









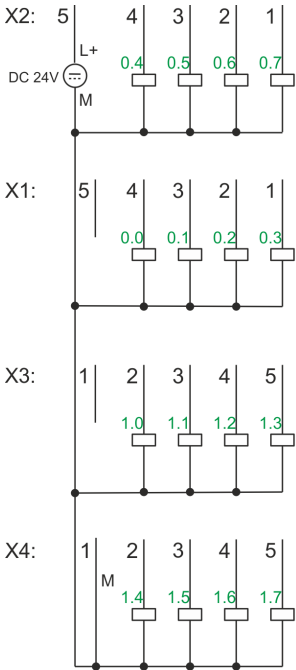







LED	Description
	LEDs green on: Backplane bus communication and module status are OK
	LED red on: Module reports an error, e.g. on overload at an output
	LED red blinks with 1Hz: Error in configuration
	LEDs green are blinking with 1Hz: Error backplane bus communication

LEDs connectors

Digital output	LED	Description
DO +0.0 ... DO +0.7	 green	Digital output Q+0.0 ... 0.7 has "1" signal
		Digital output Q+0.0 ... 0.7 has "0" signal
DO +1.0 ... DO +1.7	 green	Digital output Q+1.0 ... 1.7 has "1" signal
		Digital output Q+1.0 ... 1.7 has "0" signal

Pin assignment



X	Pin	Function	Type	LED	Description
X2:	1	+0.7	O	 green	Digital output DO 7
	2	+0.6	O	 green	Digital output DO 6
	3	+0.5	O	 green	Digital output DO 5
	4	+0.4	O	 green	Digital output DO 4
	5	DC 24V	I		Power supply DC 24V (L+)
X1:	1	+0.3	O	 green	Digital output DO 3
	2	+0.2	O	 green	Digital output DO 2
	3	+0.1	O	 green	Digital output DO 1
	4	+0.0	O	 green	Digital output DO 0
	5	-	-		reserved
X3:	1	-	-		reserved
	2	+1.0	O	 green	Digital output DO 8
	3	+1.1	O	 green	Digital output DO 9
	4	+1.2	O	 green	Digital output DO 10
	5	+1.3	O	 green	Digital output DO 11
X4:	1	0V	O		Power supply ground
	2	+1.4	O	 green	Digital output DO 12
	3	+1.5	O	 green	Digital output DO 13
	4	+1.6	O	 green	Digital output DO 14
	5	+1.7	O	 green	Digital output DO 15

I: Input, O: Output

 **CAUTION**
Feeding in voltage at an output is not allowed and can destroy the module!

Input area

No byte of the input area is used by the module.

M22-1BH00 - DO 16xDC 24V 0.5A

Output area

Addr.	Name	Byte	Function
+0	PIQ	0	Status of the outputs <ul style="list-style-type: none"> ■ Bit 0: DO 0 ■ Bit 1: DO 1 ■ Bit 2: DO 2 ■ Bit 3: DO 3 ■ Bit 4: DO 4 ■ Bit 5: DO 5 ■ Bit 6: DO 6 ■ Bit 7: DO 7
		1	Status of the outputs <ul style="list-style-type: none"> ■ Bit 0: DO 8 ■ Bit 1: DO 9 ■ Bit 2: DO 10 ■ Bit 3: DO 11 ■ Bit 4: DO 12 ■ Bit 5: DO 13 ■ Bit 6: DO 14 ■ Bit 7: DO 15

Parameter data

The module has the following parameter data, which can be set in the hardware configuration:

- Diagnostic interrupt
 - When enabled, a diagnostic interrupt is triggered when an output is overloaded.



Regardless of the parametrization, the red LED  of the status bar lights up on overload. The LED lights up as long as there is an overload.

3.2.1 Diagnostic data

Via the parametrization you may activate a diagnostic interrupt for the module. With a diagnostic interrupt the module serves for diagnostic data for `diagnosticincoming`. As soon as the reason for releasing a diagnostic interrupt is no longer present, the diagnostic interrupt_{going} automatically takes place. Via record set 01h the diagnostic data can be accessed.

Name	Bytes	Function	Default
ERR_A	1	Diagnostic	00h
MODTYP	1	Module information	0Fh
ERR_C	1	reserved	00h
ERR_D	1	reserved	00h
CHTYP	1	Channel type	72h
NUMBIT	1	Number diagnostic bits per channel	00h
NUMCH	1	Number channels of the module	00h
CHERR	1	reserved	00h
CH0ERR...CH7ERR	8	reserved	00h
DIAG_US	4	µs ticker (32bit)	00h

ERR_A Diagnostic

Byte	Bit 7 ... 0
0	<ul style="list-style-type: none"> ■ Bit 0: set at module failure ■ Bit 1: set at internal error ■ Bit 2: set at external error ■ Bit 3: reserved ■ Bit 4: set at overload at an output ■ Bit 6 ... 5: reserved ■ Bit 7: set at error in parametrization

MODTYP Module information

Byte	Bit 7 ... 0
0	<ul style="list-style-type: none"> ■ Bit 3 ... 0: module class <ul style="list-style-type: none"> – 1111b: digital module ■ Bit 7 ... 4: reserved

CHTYP Channel type

Byte	Bit 7 ... 0
0	<ul style="list-style-type: none"> ■ Bit 6 ... 0: Channel type <ul style="list-style-type: none"> – 72h: Digital output ■ Bit 7: reserved

NUMBIT Diagnostic bits

Byte	Bit 7 ... 0
0	Number of diagnostic bits per channel (here 00h)

M22-1BH00 - DO 16xDC 24V 0.5A > Diagnostic data

NUMCH Channels

Byte	Bit 7 ... 0
0	Number of channels of the module (here 00h)

DIAG_US μ s ticker

Byte	Bit 7 ... 0
0...3	Value of the μ s ticker at the moment of the diagnostic <ul style="list-style-type: none">■ In the System MICRO module there is a timer (μs ticker). With PowerON the timer starts counting with 0. After $2^{32}-1\mu$s the timer starts with 0 again.

3.2.2 Technical data

Order no.	M22-1BH00
Type	SM M22 - Digital output
Module ID	0114 2F50
Current consumption/power loss	
Current consumption from backplane bus	80 mA
Power loss	0.7 W
Technical data digital outputs	
Number of outputs	16
Cable length, shielded	1000 m
Cable length, unshielded	600 m
Rated load voltage	DC 20.4...28.8 V
Current consumption from load voltage L+ (without load)	20 mA
Total current per group, horizontal configuration, 40°C	8 A
Total current per group, horizontal configuration, 60°C	8 A
Total current per group, vertical configuration	8 A
Output current at signal "1", rated value	0.5 A
Signal logic output	Sourcing output
Output delay of "0" to "1"	30 µs
Output delay of "1" to "0"	175 µs
Minimum load current	-
Lamp load	10 W
Parallel switching of outputs for redundant control of a load	not possible
Parallel switching of outputs for increased power	not possible
Actuation of digital input	✓
Switching frequency with resistive load	max. 1000 Hz
Switching frequency with inductive load	max. 0.5 Hz
Switching frequency on lamp load	max. 10 Hz
Internal limitation of inductive shut-off voltage	L+ (-45 V)
Short-circuit protection of output	yes, electronic
Trigger level	1 A
Number of operating cycle of relay outputs	-
Switching capacity of contacts	-
Output data size	16 Bit
Status information, alarms, diagnostics	
Status display	green LED per channel
Interrupts	yes, parameterizable
Process alarm	no
Diagnostic interrupt	yes, parameterizable

M22-1BH00 - DO 16xDC 24V 0.5A > Technical data

Order no.	M22-1BH00
Diagnostic functions	yes, parameterizable
Diagnostics information read-out	possible
Supply voltage display	green LED
Group error display	red LED
Channel error display	none
Isolation	
Between channels	-
Between channels of groups to	-
Between channels and backplane bus	✓
Insulation tested with	DC 500 V
Datasizes	
Input bytes	0
Output bytes	2
Parameter bytes	0
Diagnostic bytes	20
Housing	
Material	PPE / PPE GF10
Mounting	Profile rail 35 mm
Mechanical data	
Dimensions (WxHxD)	26 mm x 88 mm x 71 mm
Net weight	96 g
Weight including accessories	96 g
Gross weight	109 g
Environmental conditions	
Operating temperature	0 °C to 60 °C
Storage temperature	-25 °C to 70 °C
Certifications	
UL certification	yes
KC certification	yes
UKCA certification	yes
ChinaRoHS certification	yes

3.3 M22-1HF10 - DO 8xRelay

Properties

The module detects the binary control signals from the higher-level bus system and transports them to the process level via the relay outputs. It has 8 channels and the status of each channel is monitored via LEDs.

- 8 digital outputs isolated to the backplane bus
 - in groups of two, each with a common terminal
 - isolated between channels and backplane bus
 - isolated between channels of groups
- DC30V / AC230V, 2A
- Status indication of the channels via LEDs

Structure

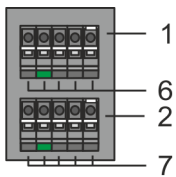

- 1 X2: Terminal DO (R2/+0.2, R3/+0.3)
- 2 X1: Terminal DO (R0/+0.0, R1/+0.1)
- 3 Status bar periphery module
- 4 X3: Terminal DO (R4/+0.4, R5/+0.5)
- 5 X4: Terminal DO (R6/+0.6, R7/+0.7)
- 6 X2: LEDs DO (R2/+0.2, R3/+0.3)
- 7 X1: LEDs DO (R0/+0.0, R1/+0.1)
- 8 X3: LEDs DO (R4/+0.4, R5/+0.5)
- 9 X4: LEDs DO (R6/+0.6, R7/+0.7)

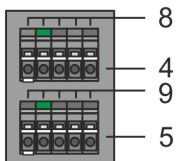
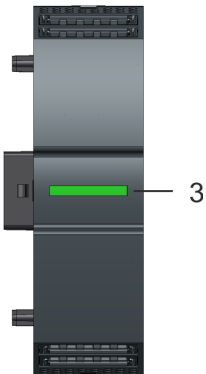



Status bar

LED	Description
	LEDs green on: Backplane bus communication and module status are OK
	LED red on: Module reports an error with overload, short circuit or overheat
	LED red blinks with 1Hz: Error in configuration
	LEDs green are blinking with 1Hz: Error backplane bus communication







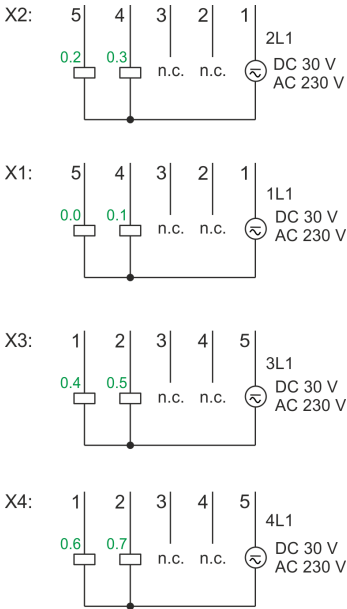

M22-1HF10 - DO 8xRelay

LEDs connectors

Relay output	LED	Description
DO +0.0 ... DO +0.7	 green	Relay output Q+0.0 ... 0.7 has "1" signal
		Relay output Q+0.0 ... 0.7 has "0" signal

Pin assignment



	Pin	Function	Type	LED	Description
X2:	1	2L1	O	-	Relay output DO 2 and DO 3
	2	-	-	-	must not be connected
	3	-	-	-	must not be connected
	4	+0.3	O	 green	Relay output DO 3
	5	+0.2	O	 green	Relay output DO 2
X1:	1	1L1	O	-	Relay output DO 0 und DO 1
	2	-	-	-	must not be connected
	3	-	-	-	must not be connected
	4	+0.1	O	 green	Relay output DO 1
	5	+0.0	O	 green	Relay output DO 0
X3:	1	+0.4	O	 green	Relay output DO 4
	2	+0.5	O	 green	Relay output DO 5
	3	-	-	-	must not be connected
	4	-	-	-	must not be connected
	5	3L1	O	-	Relay output DO 4 and DO 5
X4:	1	+0.6	O	 green	Relay output DO 6
	2	+0.7	O	 green	Relay output DO 7
	3	-	-	-	must not be connected
	4	-	-	-	must not be connected
	5	4L1	O	-	Relay output DO 6 and DO 7

O: Output



DANGER

- Due to the hardware the free pins must not be connected!
- The mixed operation of touch and non touch voltages is not permitted!



When using inductive load please take a suitable protector (see installation guidelines).

Maximum load / Service life (typical)

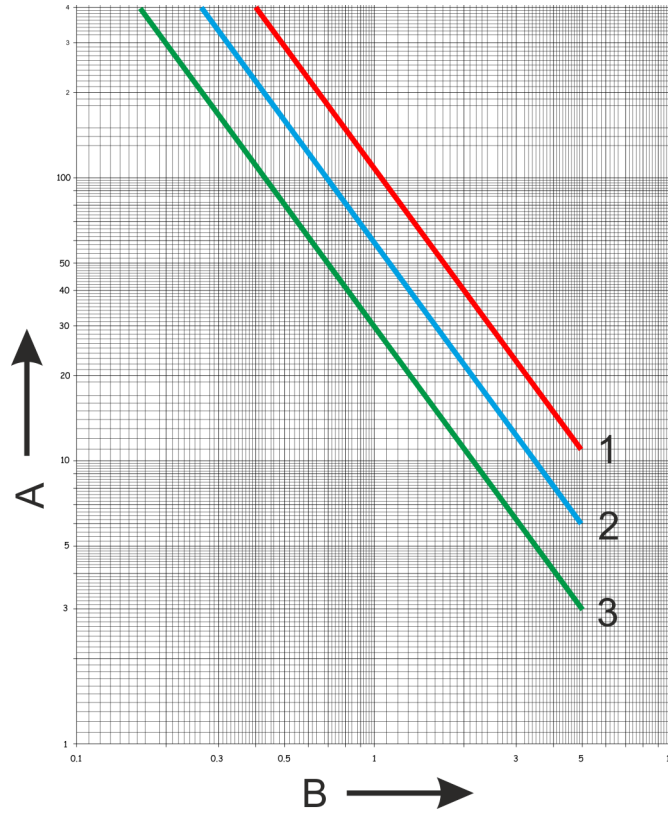

- A Operating cycles (x 10⁴)
- B Current in A
- 1 DC 30V resistive load
- 2 AC 250V resistive load, DC 30V L/R = 7ms
- 3 AC 250V cosφ = 0.4

Input area

No byte of the input area is used by the module.

Output area

Addr.	Name	Byte	Function
+0	PIQ	0	Status of the outputs <ul style="list-style-type: none"> ■ Bit 0: Relay output DO 0 ■ Bit 1: Relay output DO 1 ■ Bit 2: Relay output DO 2 ■ Bit 3: Relay output DO 3 ■ Bit 4: Relay output DO 4 ■ Bit 5: Relay output DO 5 ■ Bit 6: Relay output DO 6 ■ Bit 7: Relay output DO 7

3.3.1 Technical data

Order no.	M22-1HF10
Type	SM M22 - Digital Output
Module ID	0115 AFC8
Current consumption/power loss	
Current consumption from backplane bus	140 mA
Power loss	1.5 W
Technical data digital outputs	
Number of outputs	8
Cable length, shielded	1000 m
Cable length, unshielded	600 m
Rated load voltage	DC 30 V/ AC 230 V
Current consumption from load voltage L+ (without load)	-
Total current per group, horizontal configuration, 40°C	4 A
Total current per group, horizontal configuration, 60°C	4 A
Total current per group, vertical configuration	4 A
Output current at signal "1", rated value	2 A
Signal logic output	Isolated
Output delay of "0" to "1"	10 ms
Output delay of "1" to "0"	5 ms
Minimum load current	-
Lamp load	-
Parallel switching of outputs for redundant control of a load	not possible
Parallel switching of outputs for increased power	not possible
Actuation of digital input	-
Switching frequency with resistive load	max. 0.33 Hz
Switching frequency with inductive load	max. 0.33 Hz
Switching frequency on lamp load	max. 0.33 Hz
Internal limitation of inductive shut-off voltage	-
Short-circuit protection of output	-
Trigger level	-
Number of operating cycle of relay outputs	-
Switching capacity of contacts	5 A
Output data size	8 Bit
Status information, alarms, diagnostics	
Status display	green LED per channel
Interrupts	no
Process alarm	no
Diagnostic interrupt	no

Order no.	M22-1HF10
Diagnostic functions	no
Diagnostics information read-out	none
Supply voltage display	green LED
Group error display	red LED
Channel error display	none
Isolation	
Between channels	-
Between channels of groups to	2
Between channels and backplane bus	✓
Insulation tested with	AC 2200 V
Datasizes	
Input bytes	0
Output bytes	1
Parameter bytes	0
Diagnostic bytes	0
Housing	
Material	PPE / PPE GF10
Mounting	Profile rail 35 mm
Mechanical data	
Dimensions (WxHxD)	26 mm x 88 mm x 71 mm
Net weight	110 g
Weight including accessories	110 g
Gross weight	123 g
Environmental conditions	
Operating temperature	0 °C to 60 °C
Storage temperature	-25 °C to 70 °C
Certifications	
UL certification	yes
KC certification	yes
UKCA certification	yes
ChinaRoHS certification	yes

M23-1BH00 - DI8/DO8 0.5A

3.4 M23-1BH00 - DI8/DO8 0.5A

Properties

The module is a mixed module. It has 8 input channels and 8 output channels. The status of the channels is indicated by LEDs.

- 8 digital inputs and 8 digital outputs electrically isolated from the backplane bus
- Status indication of the channels via LEDs
- Diagnostic function can be parametrized in case of overload

Structure

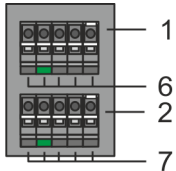

- 1 X2: Terminal DO +0.4 ... +0.7
- 2 X1: Terminal DO +0.0 ... +0.3
- 3 Status bar periphery module
- 4 X3: Terminal DI +1.0 ... +1.3
- 5 X4: Terminal DI +1.4 ... +1.7
- 6 X2: LEDs DO +0.4 ... +0.7
- 7 X1: LEDs DO +0.0 ... +0.3
- 8 X3: LEDs DI +1.0 ... +1.3
- 9 X4: LEDs DI +1.4 ... +1.7

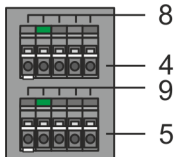
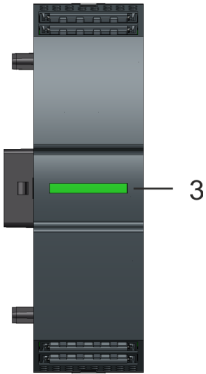

Status bar

LED	Description
	LEDs green on: Backplane bus communication and module status are OK
	LED red on: Module reports an error, e.g. on overload at an output
	LED red blinks with 1Hz: Error in configuration
	LEDs green are blinking with 1Hz: Error backplane bus communication

LEDs connectors

Digital output	LED	Description
DO +0.0 ... DO +0.7	<input checked="" type="checkbox"/> green	Digital output Q+0.0 ... 0.7 has "1" signal
	<input type="checkbox"/>	Digital output Q+0.0 ... 0.7 has "0" signal

Digital input	LED	Description
DI +1.0 ... DI +1.7	<input checked="" type="checkbox"/> green	Digital input I+1.0 ... 1.7 has "1" signal
	<input type="checkbox"/>	Digital input I+1.0 ... 1.7 has "0" signal

Pin assignment

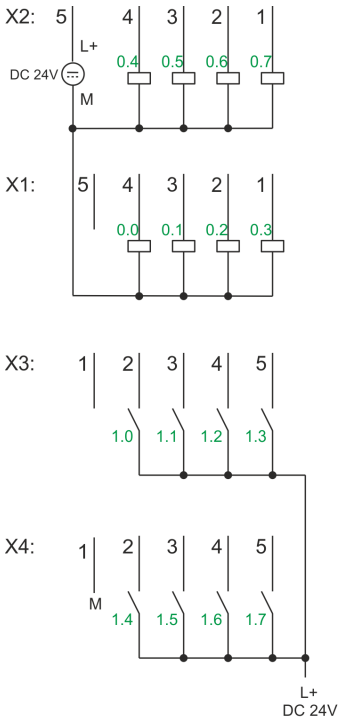

X	Pin	Function	Type	LED	Description
X2:	1	+0.7	O	<input checked="" type="checkbox"/> green	Digital output DO 7
	2	+0.6	O	<input checked="" type="checkbox"/> green	Digital output DO 6
	3	+0.5	O	<input checked="" type="checkbox"/> green	Digital output DO 5
	4	+0.4	O	<input checked="" type="checkbox"/> green	Digital output DO 4
	5	DC24V	I		Load voltage DC 24V for DO (L+)
X1:	1	+0.3	O	<input checked="" type="checkbox"/> green	Digital output DO 3
	2	+0.2	O	<input checked="" type="checkbox"/> green	Digital output DO 2
	3	+0.1	O	<input checked="" type="checkbox"/> green	Digital output DO 1
	4	+0.0	O	<input checked="" type="checkbox"/> green	Digital output DO 0
	5	-	-		reserved
X3:	1	-	-		reserved
	2	+1.0	I	<input checked="" type="checkbox"/> green	Digital input DI 4
	3	+1.1	I	<input checked="" type="checkbox"/> green	Digital input DI 5
	4	+1.2	I	<input checked="" type="checkbox"/> green	Digital input DI 6
	5	+1.3	I	<input checked="" type="checkbox"/> green	Digital input DI 7
X4:	1	0V	I		Ground DI
	2	+1.4	I	<input checked="" type="checkbox"/> green	Digital input DI 0
	3	+1.5	I	<input checked="" type="checkbox"/> green	Digital input DI 1
	4	+1.6	I	<input checked="" type="checkbox"/> green	Digital input DI 2
	5	+1.7	I	<input checked="" type="checkbox"/> green	Digital input DI 3

M23-1BH00 - DI8/DO8 0.5A

Input area

Addr.	Name	Byte	Function
+0	PII	0	Status of the inputs <ul style="list-style-type: none"> ■ Bit 0: DI 0 ■ Bit 1: DI 1 ■ Bit 2: DI 2 ■ Bit 3: DI 3 ■ Bit 4: DI 4 ■ Bit 5: DI 5 ■ Bit 6: DI 6 ■ Bit 7: DI 7

Output area

Addr.	Name	Byte	Function
+0	PIQ	0	Status of the outputs <ul style="list-style-type: none"> ■ Bit 0: DO 0 ■ Bit 1: DO 1 ■ Bit 2: DO 2 ■ Bit 3: DO 3 ■ Bit 4: DO 4 ■ Bit 5: DO 5 ■ Bit 6: DO 6 ■ Bit 7: DO 7

Parameter data

The module has the following parameter data, which can be set in the hardware configuration:

- Diagnostic interrupt
 - When enabled, a diagnostic interrupt is triggered when an output is overloaded.



Regardless of the parametrization, the red LED  of the status bar lights up on overload. The LED lights up as long as there is an overload.

3.4.1 Diagnostic data

Via the parametrization you may activate a diagnostic interrupt for the module. With a diagnostic interrupt the module serves for diagnostic data for `diagnosticincoming`. As soon as the reason for releasing a diagnostic interrupt is no longer present, the diagnostic interrupt_{going} automatically takes place. Via record set 01h the diagnostic data can be accessed.

Name	Bytes	Function	Default
ERR_A	1	Diagnostic	00h
MODTYP	1	Module information	0Fh
ERR_C	1	reserved	00h
ERR_D	1	reserved	00h
CHTYP	1	Channel type	72h
NUMBIT	1	Number diagnostic bits per channel	00h
NUMCH	1	Number channels of the module	00h
CHERR	1	reserved	00h
CH0ERR...CH7ERR	8	reserved	00h
DIAG_US	4	µs ticker (32bit)	00h

ERR_A Diagnostic

Byte	Bit 7 ... 0
0	<ul style="list-style-type: none"> ■ Bit 0: set at module failure ■ Bit 1: set at internal error ■ Bit 2: set at external error ■ Bit 3: reserved ■ Bit 4: set at overload at an output ■ Bit 6 ... 5: reserved ■ Bit 7: set at error in parametrization

MODTYP Module information

Byte	Bit 7 ... 0
0	<ul style="list-style-type: none"> ■ Bit 3 ... 0: module class <ul style="list-style-type: none"> – 1111b: digital module ■ Bit 7 ... 4: reserved

CHTYP Channel type

Byte	Bit 7 ... 0
0	<ul style="list-style-type: none"> ■ Bit 6 ... 0: Channel type <ul style="list-style-type: none"> – 72h: Digital output ■ Bit 7: reserved

NUMBIT Diagnostic bits

Byte	Bit 7 ... 0
0	Number of diagnostic bits per channel (here 00h)

M23-1BH00 - DI8/DO8 0.5A > Diagnostic data

NUMCH Channels

Byte	Bit 7 ... 0
0	Number of channels of the module (here 00h)

DIAG_US μ s ticker

Byte	Bit 7 ... 0
0...3	Value of the μ s ticker at the moment of the diagnostic <ul style="list-style-type: none">■ In the System MICRO module there is a timer (μs ticker). With PowerON the timer starts counting with 0. After $2^{32}-1\mu$s the timer starts with 0 again.

3.4.2 Technical data

Order no.	M23-1BH00
Type	SM M23 - Digital in-/output
Module ID	0015 3F49
Current consumption/power loss	
Current consumption from backplane bus	80 mA
Power loss	0.7 W
Technical data digital inputs	
Number of inputs	8
Cable length, shielded	1000 m
Cable length, unshielded	600 m
Rated load voltage	DC 24 V
Current consumption from load voltage L+ (without load)	25 mA
Rated value	DC 20.4...28.8 V
Input voltage for signal "0"	DC 0...5 V
Input voltage for signal "1"	DC 15...28.8 V
Input voltage hysteresis	-
Signal logic input	Sinking input
Frequency range	-
Input resistance	-
Input current for signal "1"	3 mA
Connection of Two-Wire-BEROs possible	✓
Max. permissible BERO quiescent current	0.5 mA
Input delay of "0" to "1"	3 ms
Input delay of "1" to "0"	3 ms
Number of simultaneously utilizable inputs horizontal configuration	8
Number of simultaneously utilizable inputs vertical configuration	8
Input characteristic curve	IEC 61131-2, type 1
Initial data size	8 Bit
Technical data digital outputs	
Number of outputs	8
Cable length, shielded	1000 m
Cable length, unshielded	600 m
Rated load voltage	DC 20.4...28.8 V
Reverse polarity protection of rated load voltage	-
Current consumption from load voltage L+ (without load)	20 mA
Total current per group, horizontal configuration, 40°C	4 A

Order no.	M23-1BH00
Total current per group, horizontal configuration, 60°C	4 A
Total current per group, vertical configuration	4 A
Output current at signal "1", rated value	0.5 A
Output delay of "0" to "1"	30 µs
Output delay of "1" to "0"	175 µs
Minimum load current	-
Lamp load	10 W
Parallel switching of outputs for redundant control of a load	not possible
Parallel switching of outputs for increased power	not possible
Actuation of digital input	✓
Switching frequency with resistive load	max. 1000 Hz
Switching frequency with inductive load	max. 0.5 Hz
Switching frequency on lamp load	max. 10 Hz
Internal limitation of inductive shut-off voltage	L+ (-45 V)
Short-circuit protection of output	yes, electronic
Trigger level	1 A
Number of operating cycle of relay outputs	-
Switching capacity of contacts	-
Output data size	8 Bit
Status information, alarms, diagnostics	
Status display	green LED per channel
Interrupts	yes, parameterizable
Process alarm	no
Diagnostic interrupt	yes, parameterizable
Diagnostic functions	yes, parameterizable
Diagnostics information read-out	possible
Module state	green LED
Module error display	red LED
Channel error display	none
Isolation	
Between channels	-
Between channels of groups to	-
Between channels and backplane bus	✓
Insulation tested with	DC 500 V
Datasizes	
Input bytes	1
Output bytes	1
Parameter bytes	0

Order no.	M23-1BH00
Diagnostic bytes	20
Housing	
Material	PPE / PPE GF10
Mounting	Profile rail 35 mm
Mechanical data	
Dimensions (WxHxD)	26 mm x 88 mm x 71 mm
Net weight	92 g
Weight including accessories	92 g
Gross weight	105 g
Environmental conditions	
Operating temperature	0 °C to 60 °C
Storage temperature	-25 °C to 70 °C
Certifications	
UL certification	yes
KC certification	yes
UKCA certification	yes
ChinaRoHS certification	yes